

A-B



SUMITOMO

CARBIDE - CBN - DIAMOND

22|23

CUTTING MATERIALS

Insert Selection

A



A1–A20

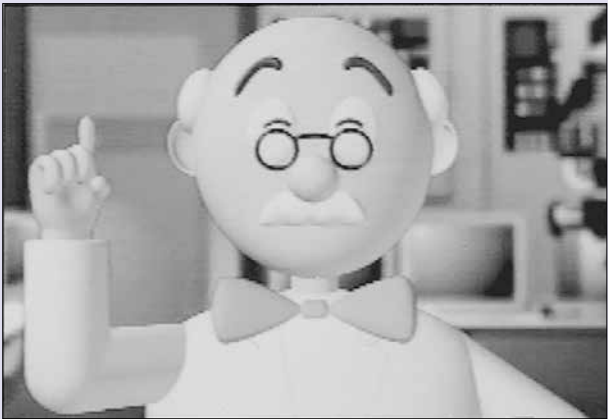

Insert Selection

Insert Selection

Sumitomo Grades (Turning)	A2
Sumitomo Grades (Milling)	A3

Chipbreaker and Grade Selection

Steel Turning Inserts	A 4–7
Stainless Steel Turning Inserts	A 8–9
Cast Iron Turning Inserts	A10–11
Exotic Alloy Inserts	A12–13
Hardened Steel Turning Inserts	A14–15
Non-Ferrous Metal Turning Inserts	A16–17
Small Product Machining	A18–19

Selection of Sumitomo Grades (Turning)

Insert Selection

Work Material	P General Steel (Carbon Steel, Alloy Steel), Soft Steel						M Stainless Steel						K Cast Iron			
	Wear Resistance ← Fracture Resistance						Wear Resistance ← Fracture Resistance						Wear Resistance ← Fracture Resistance			
	Q	P01	P10	P20	P30	P40	Q	M01	M10	M20	M30	M40	Q	K01	K10	K20
Coated Carbide	AC8015P						AC6020M						AC4010K			
	New AC8020P						AC6030M						AC4015K			
Small Product Machining	AC8025P						AC6040M						AC420K			
	AC8035P						AC630M						AC8025P			
Coated Cermet	AC1030U						AC1030U						AC1030U			
	AC530U						AC530U						AC530U			
Cermet	T1500Z															
	New T2500Z															
	T3000Z															
Carbide	T1000A						T1000A						T1000A			
	T1500A						T1500A									
	T2500A															
Uncoated CBN													G10E			
													BN7000			
													New BNC8115			
Coated CBN													New BNS8125			
													BNC500			

Work Material	S Exotic Alloy					H Hardened Steel				Work Material	N Non-Ferrous Metal					
	Wear Resistance ← Fracture Resistance					Wear Resistance ← Fracture Resistance					Wear Resistance ← Fracture Resist.					
	Q	S01	S10	S20	S30	Q	H01	H10	H20		H30	Q	N01	N10	N20	N30
Coated Carbide	New AC5005S									Carbide	H1					
	AC5015S					AC503U					PCD	DA90				
	AC5025S											DA150				
Carbide	EH510									Coated CBN	DA1000					
	EH520					BNC2010					New AC5005S					
Uncoated CBN						BNC2020				Powdered Metal	T1000A					
						New BNC2125					Coated Carbide	New BN7115				
						New BNC2115						BN7000				
Uncoated CBN	NCB100					BN1000				Cemented Carbides and Hard Brittle Materials	NPD10					
	BN7000					BN2000					PCD	DA90				
	BNS800					BNX20										
					BN350											

Selection of Sumitomo Grades (Milling)

Insert Selection

Work Material	P General Steel (Carbon Steel, Alloy Steel), Soft Steel						M Stainless Steel						K Cast Iron				
	Wear Resistance ← Fracture Resistance						Wear Resistance ← Fracture Resistance						Wear Resistance ← Fracture Resistance				
	Q	P01	P10	P20	P30	P40	Q	M01	M10	M20	M30	M40	Q	K01	K10	K20	K30
Coated Carbide																	
Cermet																	
Carbide																	
Uncoated CBN Coated CBN																	

Work Material	S Exotic Alloy						H Hardened Steel					N Non-Ferrous Metal				
	Wear Resistance ← Fracture Resistance						Wear Resistance ← Fracture Resistance					Wear Resistance ← Fracture Resistance				
	Q	S01	S10	S20	S30	S40	Q	H01	H10	H20	H30	Q	N01	N10	N20	N30
Coated Carbide																
Carbide																
Uncoated CBN																
PCD																

Main Chipbreakers

Negative Type

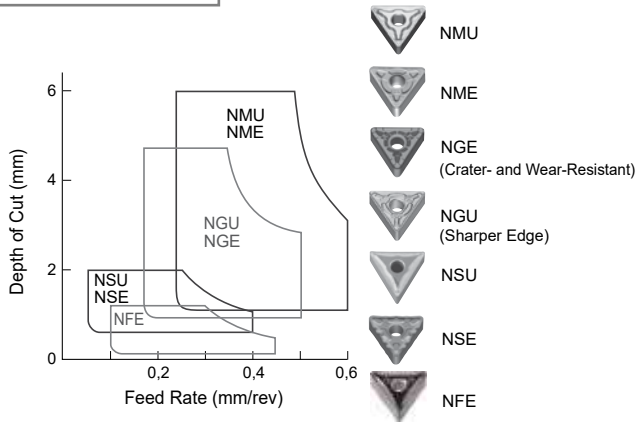

Positive Type

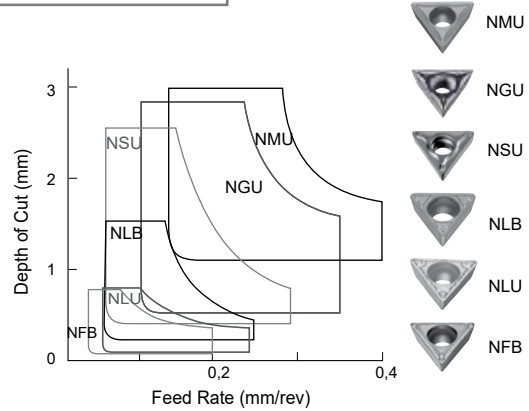

Sub-Chipbreakers

Negative Type

Chipbreakers for High-Efficiency Machining

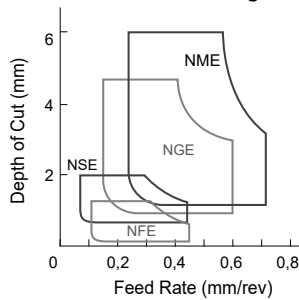

Strong Edge Chipbreakers

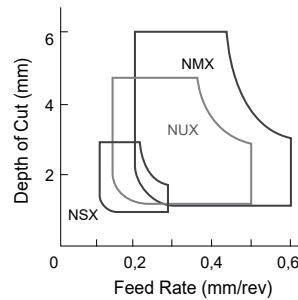

Chipbreakers for Small Depths

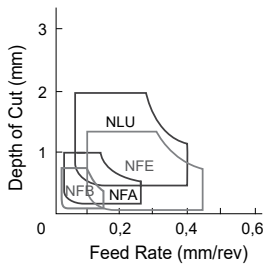

Wiper Inserts

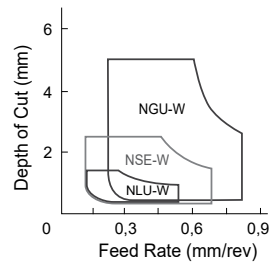

Chipbreakers for Heavy Cutting

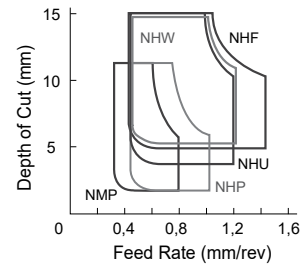

Grades

Fine Finishing to Finishing

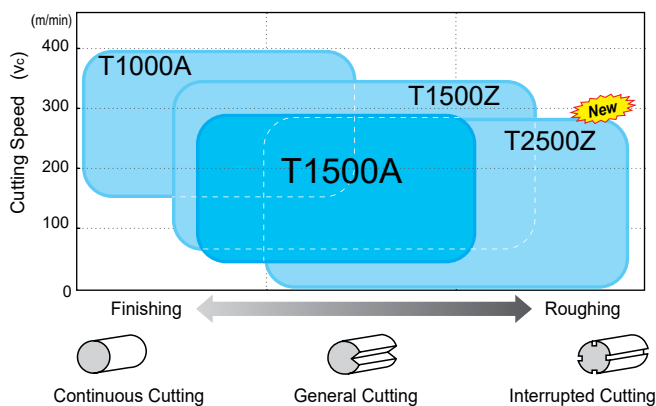

Finishing to Rough Cutting

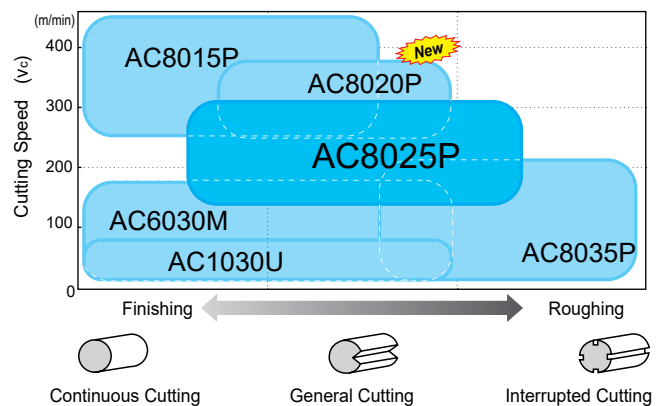

Grades

Uncoated Cermet **T1000A / T1500A / T1500Z / T2500Z** Coated Cermet **New**

- T1000A** High-hardness cermet with outstanding wear resistance and toughness. Realises high dimensional accuracy for continuous steel machining or finishing of Sintered Alloy or cast iron.
- T1500A** General-purpose cermet made from hard grains with different grain sizes, delivering functionality that provides an excellent balance of wear resistance and toughness. Also achieves good surface finish quality.
- T1500Z** Employs Brilliant Coat PVD coating with excellent lubricity to provide better wear resistance and consistent surface finishes in low-speed cutting applications such as machining of small products or low carbon steel.
- T2500Z** A new cermet substrate with excellent thermal conductivity is used to achieve outstanding thermal crack resistance. Also uses Brilliant Coat, which has excellent lubricity.

Performance

T1000A

Wear Resistance

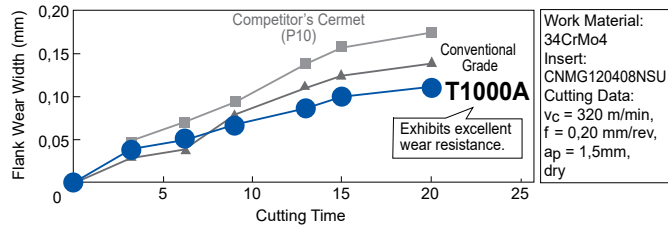

Fracture Resistance

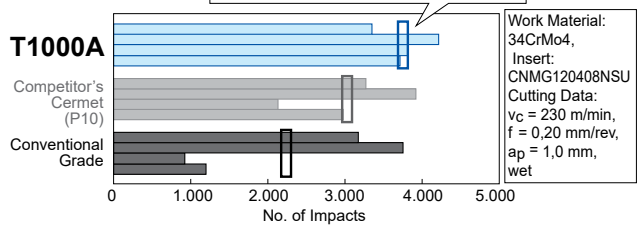

T1500A

Wear Resistance

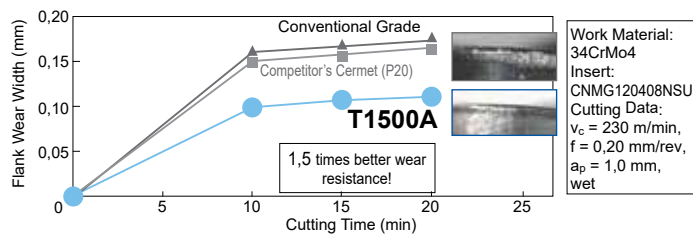

Machined Surface Finish



T1500Z

Wear Resistance

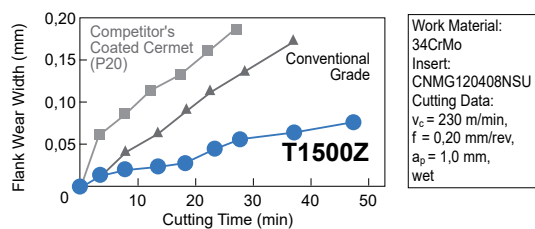

Machined Surface Finish

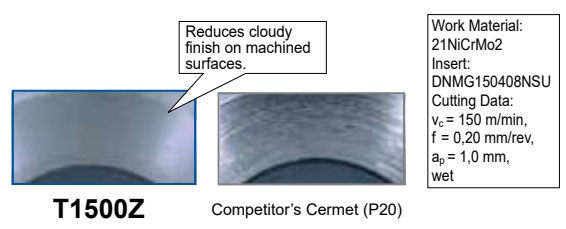

T2500Z

Wear Resistance

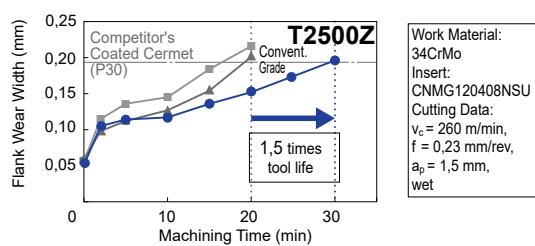

Fracture Resistance

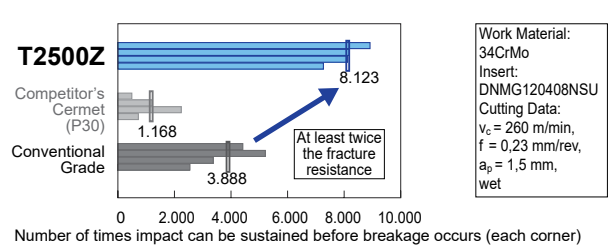

Recommended Cutting Conditions

(Min. - Optimum - Max.)

Work Material	Cutting Process	Chipbreaker	Grades	Depth of Cut (mm)	Feed Rate (mm/rev)	Cutting Speed (m/min)
Soft Steel	Fine Finishing	NFA / NFL	T1500Z	0,2–0,5–1,0	0,05–0,15–0,25	150–280–400
	Finishing	NLU	T3000Z	0,3–1,0–1,8	0,08–0,20–0,35	150–280–400
Alloy Steel Carbon Steel	Fine Finishing	NFA / NFL	T1500A	0,2–0,5–1,0	0,05–0,15–0,25	100–200–300
	Finishing	NSU / NSE	T1500A	0,5–1,0–2,0	0,08–0,20–0,35	100–200–300
	Medium	NGU	T1500Z	0,8–2,2–4,0	0,15–0,25–0,50	100–200–300
High Carbon Steel Carbon Steel	Fine Finishing	NFA / NFL	T1000A	0,2–0,5–1,0	0,05–0,15–0,25	50–150–250
	Finishing	NSU / NSE	T1500Z	0,5–1,0–2,0	0,08–0,20–0,35	50–150–250
	Medium	NGU	T1500Z	0,8–2,2–4,0	0,15–0,25–0,50	50–150–250

ABSOTECH

ABSOTECH

New

ABSOTECH

ABSOTECH

ABSOTECH

Grades

AC8015P / AC8020P / AC8025P / AC8035P / AC1030U

Covers a wide range of machining applications from high-speed cutting to interrupted cutting and small lathe machining.

- AC8015P** Development of crater damage is suppressed by controlling the orientation of the alumina crystal grains. Achieves long, stable tool life during high-speed and high feed cutting.
- AC8020P** Alumina coating with even higher strength balances outstanding stability and wear resistance in mill-scale work on forged material. Gold-colored coating makes used corners easily identifiable.
- AC8025P** The 1st recommendation grade for turning steel. Surface smoothing technology significantly suppresses adhesion of work material components. Achieves long, stable tool life with various cutting speeds and work materials.
- AC8035P** Tensile stress removal of the coating layer greatly improves fracture resistance. Achieves long, stable tool life during heavy interrupted cutting.
- AC1030U** Employs a new PVD coating and a dedicated tough carbide substrate. High-quality cutting edge grade suppresses adhesion and micro-chipping, realizing excellent machined surface quality.

Performance

AC8015P

Alumina crystal grain orientation control technology suppresses crater damage due to chip abrasion.

<p>Conventional Tool</p> <p>5 min TiCN layer exposed</p> <p>14 min End of tool life</p> <p>Crater damage progression due to peeling of alumina layer.</p> <p>Work Material: 100Cr6 //(external continuous) Insert: CNMG120408NGU Cutting Data: $v_c = 300$ m/min, $f = 0,3$ mm/rev, $a_p = 1,5$ mm, wet</p>	<p>AC8015P</p> <p>5 min Minor wear</p> <p>17 min TiCN layer exposed</p> <p>20 min End of tool life</p> <p>Suppresses crater damage due to chip abrasion</p> <p>Twice the crater wear resistance</p>
---------------------------------------------------------------------------------------------------------------------------------------------------------------------------------------------------------------------------------------------------------------------------------------------------------------------------------------------------------------------	------------------------------------------------------------------------------------------------------------------------------------------------------------------------------------------------------------------------

AC8020P

Alumina coating with even higher strength suppresses chipping.

<p>Conventional Tool</p> <p>400 impacts Minimal chipping</p> <p>1600 impacts Tool life</p> <p>Chipping</p> <p>Work Material: 34CrMo4 //(incl. intermittent forge sections) Insert: CNMG120408NGU Cutting Data: $v_c = 250$ m/min, $f = 0,3$ mm/rev, $a_p = 1,5$ mm, wet</p>	<p>AC8020P</p> <p>400 impacts Minor damage</p> <p>1600 impacts Minor damage</p> <p>4000 impacts Minimal chipping</p> <p>Balance of high wear resistance and stability</p> <p>2,5x chipping resistance or more</p>
-------------------------------------------------------------------------------------------------------------------------------------------------------------------------------------------------------------------------------------------------------------------------------------------------------------------------------------	--------------------------------------------------------------------------------------------------------------------------------------------------------------------------------------------------------------------------------------

AC8025P

Surface smoothing treatment significantly suppresses adhesion and chipping.

<p>Conventional Tool</p> <p>2 min Adhesion</p> <p>70 min Chipping</p> <p>Unable to continue</p> <p>Work Material: 15CrMo5 (Face) Insert: CNMG120408NGU Cutting Data: $v_c = 100-300$ m/min, $f = 0,3$ mm/rev, $a_p = 1,5$ m, wet</p>	<p>AC8025P</p> <p>2 min Normal wear</p> <p>70 min Minor damage only, able to continue</p> <p>120 min Minor damage only, able to continue</p> <p>Suppresses adhesion with ultra-smooth surface</p> <p>Twice the adhesion fracture resistance</p>
----------------------------------------------------------------------------------------------------------------------------------------------------------------------------------------------------------------------------------------------------------------------------------------------	--------------------------------------------------------------------------------------------------------------------------------------------------------------------------------------------------------------------------------------------------------------------

AC8035P

Special surface treatment reduces tensile stress in the coating layer, significantly suppressing breakages.

<p>Conventional Tool</p> <p>Feed Rate (mm/rev) vs No. of Impacts</p> <p>Unable to continue</p> <p>Work Material: 34CrMo4 (external interrupted) Insert: CNMG120408NGU Cutting Data: $v_c = 160$ m/min, $f = 0,2-0,3$ mm/rev, $a_p = 2,0$ mm, dry</p>	<p>AC8035P</p> <p>Feed Rate (mm/rev) vs No. of Impacts</p> <p>All corners able to continue</p> <p>Suppresses crack growth and breakages by reducing tensile stress</p> <p>Twice the fracture resistance</p>
------------------------------------------------------------------------------------------------------------------------------------------------------------------------------------------------------------------------------------------------------------------------------------------------------	--------------------------------------------------------------------------------------------------------------------------------------------------------------------------------------------------------------------

Grades and Chip breaker Selection Guide

1st Recommended Grade	
General Purpose	AC8025P



1st Recommendation
NGU

	Chipbreakers for High-efficiency Machining		Main Chipbreakers		Strong Cutting Edge Chipbreakers	
Finish – Small Depth	NFE 	NSE 	NSU 	NSX 		
General Purpose	NGE 	NGU 	NGU 	NUX 		
Rough – Larger Cutting Depth	NME 	NMU 	NMU 	NMX 		

For High-speed Continuous Machining of Mild Steel	
High Speed	AC8015P

For Heavy Interrupted Cutting Emphasizing Stability	
Interrupted Cut	AC8035P

To improve tool life at small depths of cut	NFE
To improve finishing efficiency	NSE

To improve tool life	NGU
To improve machining stability	NUX

For High-efficiency Machining of High Carbon Steel and Forged Steel	
High Efficiency	AC8020P

To increase feed rate	NGE
-----------------------	----------------

To increase cutting speed	NGU
---------------------------	----------------

P Recommended Cutting Conditions

(Min. - Optimum - Max.)

Work Material	Cutting Process	Chipbreaker	Grade	Depth of Cut (mm)	Feed Rate (mm/rev)	Cutting Speed (mm/min)
Soft Steel Low Carbon Steel (SS400, C15, etc.)	Fine Finishing	NFB, NFE	T1500Z	0,2–0,6–1,0	0,05–0,15–0,25	100–250–400
	Continuous	NGU, NGE	AC8015P	1,0–2,5–4,0	0,1–0,25–0,4	260–350–440
	General-Interrupted	NGU, NGE	AC8025P	1,0–2,5–4,0	0,2–0,35–0,5	200–260–320
	Heavy Interrupted	NMU, NME	AC8035P	1,5–4,0–6,0	0,3–0,45–0,6	140–150–220
Medium to High Carbon Steel Alloy Steel, Hard Steel (C45, 34CrMo4, etc.)	Fine Finishing	NFB, NFE	T1500Z	0,2–0,6–1,0	0,05–0,15–0,25	50–200–300
	Continuous-General	NGU, NGE	AC8020P	1,0–2,5–4,0	0,2–0,35–0,5	150–235–290
	Interrupted	NGU, NGE	AC8025P	1,0–2,5–4,0	0,2–0,35–0,5	130–165–230
	Heavy Interrupted	NMU, NME	AC8035P	1,5–4,0–6,0	0,3–0,45–0,6	90–135–160

Chipbreakers

Negative Type

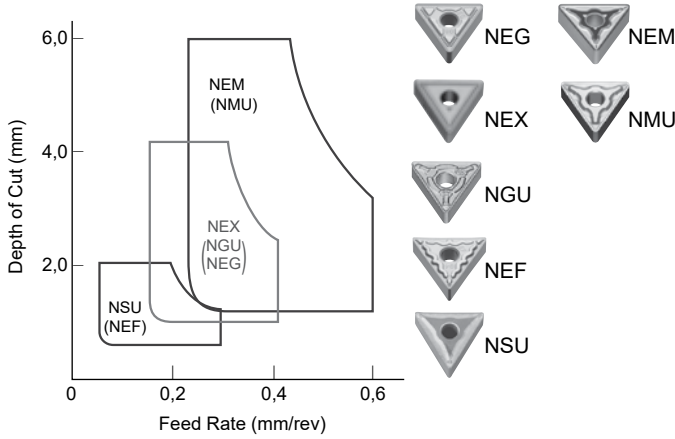

Positive Type

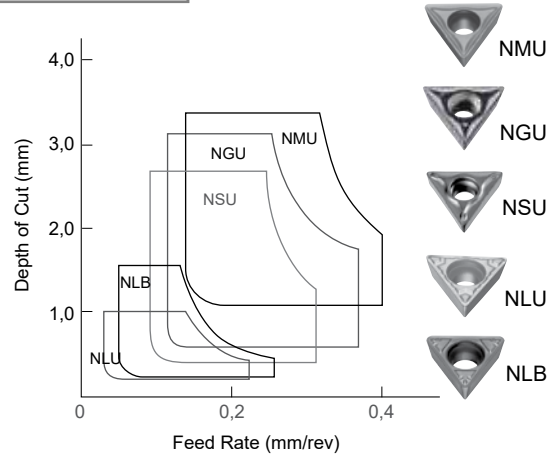

Grades

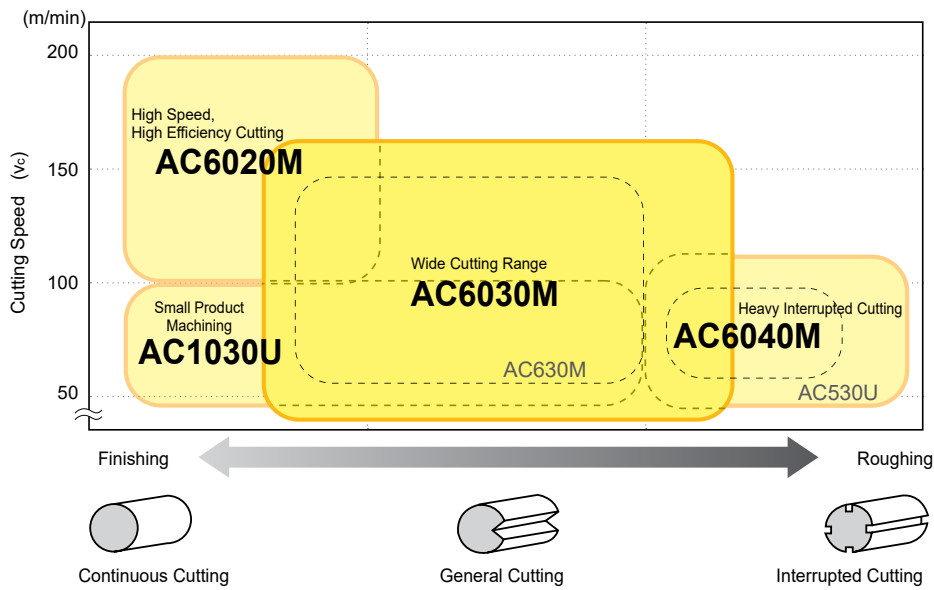

M Recommended Cutting Conditions

(Min. - Optimum - Max.)

Work Material			Cutting Range	Chipbreaker	Grade	Cutting Conditions		
						Depth of Cut a_p (mm)	Feed Rate f (mm/rev)	Cutting Speed v_c (m/min)
Cr-Based	Ferritic Materials	X6CrAl 13, X8CrNiS 18 9, X29CrS 13, X6CrMoS 17, X12CrS 13	Finishing	NEF (NSU)	AC6020M	0,5-1,5-2,0	0,05-0,15-0,25	170-230-300
			Medium	NEG · NGU · NEX	AC6030M	1,0-2,5-4,0	0,10-0,25-0,40	140-170-250
			Roughing	NEM	AC6040M	1,5-3,5-6,0	0,20-0,35-0,60	140-170-200
	Martensitic Materials	X12Cr 13, X20Cr 13, X30Cr 13, X6Cr 17, X19CrNi 17 2, X6CrNi 18 9	Finishing	NEF (NSU)	AC6020M	0,5-1,5-2,0	0,05-0,15-0,25	120-180-240
			Medium	NEG · NGU · NEX	AC6030M	1,0-2,5-4,0	0,10-0,25-0,40	100-150-200
			Roughing	NEM	AC6040M	1,5-3,5-6,0	0,20-0,35-0,60	80-130-180
Cr/Ni-Based	Austenitic Materials	X5CrNi 18 10, X2CrNi 19 11, X2CrNiMo 18 10, X4CrNiMo 17 12 2, X2CrNiMo 17 12 2, X5CrNiMo 17 13, X6CrNiTi 18 10, X7CrMo 15	Finishing	NEF (NSU)	AC6020M	0,5-1,5-2,0	0,05-0,15-0,25	120-180-240
			Medium	NEG · NGU · NEX	AC6030M	1,0-2,5-4,0	0,10-0,25-0,40	100-150-200
			Roughing	NEM	AC6040M	1,5-3,5-6,0	0,20-0,35-0,60	80-130-180
	Two-Phase (Austenite / Ferrite) Materials	X5CrNi 17 7, X2CrNi 18 9, X6CrNi 25 20, X2CrNiMoN 17 12 2, X6CrNiNb 18 10	Finishing	NEF (NSU)	AC6030M	0,5-1,5-2,0	0,05-0,15-0,25	100-145-180
			Medium	NEG · NGU · NEX	AC6030M	1,0-2,5-4,0	0,10-0,25-0,40	80-120-160
			Roughing	NEM	AC6040M	1,5-3,5-6,0	0,20-0,35-0,60	70-100-140
	Precipitation Hardening	X5CrNiCuNb 16 4, X7CrNiAl 17 7, X4CrNiMo 27 5 2, X2CrNiMoN 22 5 3, X2CrNiMoCuN 25 6 3	Finishing	NEF (NSU)	AC6030M	0,5-1,5-2,0	0,05-0,15-0,25	90-115-140
			Medium	NEG · NGU · NEX	AC6030M	1,0-2,5-4,0	0,10-0,25-0,40	70-90-110
			Roughing	NEM	AC6040M	1,5-3,5-6,0	0,20-0,35-0,60	50-80-120

Grades

ABSOTECH **ABSOTECH** **ABSOTECH** **ABSOTECH**
AC6020M / AC6030M / AC6040M / AC1030U

- AC6020M** Employs "Absotech Platinum", a new CVD coating. The first recommended grade for continuous stainless steel machining that achieves a good balance between wear resistance and fracture resistance by combining a hardened substrate with excellent wear resistance.
- AC6030M** Employs "Absotech Platinum", a new CVD coating. The first recommended grade for general machining of stainless steel that drastically reduces the occurrence of abnormal damage, which is a problem in stainless steel machining. Achieves long and stable machining thanks to the improved coating strength and excellent adhesion.
- AC6040M** Employs "Absotech Bronze", a new PVD coating and exclusive tough carbide substrate. The first recommended grade for interrupted machining of stainless steel that drastically improves the reliability in unstable machining thanks to the excellent adhesion and peel-off resistance of the new PVD coating as well as the improved fracture resistance of the exclusive carbide substrate.
- AC1030U** Employs "Absotech Bronze", a new PVD coating with a special tough carbide substrate. Achieving excellent machined surface quality with a high-quality cutting edge that reduces adhesion and micro-chipping.

Performance

AC6020M

Continuous Cutting (Medium Speed)

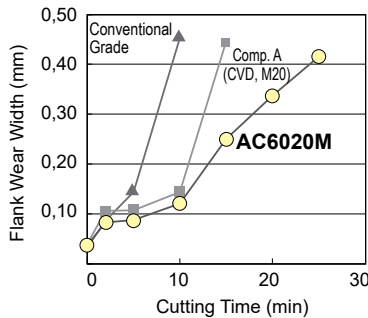

Work Material: X2CrNiMo17 13 2 Insert: CNMG 120408 NGU
 Cutting Conditions: $v_c = 150$ m/min, $f = 0,3$ mm/rev, $a_p = 2,0$ mm, wet

Continuous Cutting (High Speed)

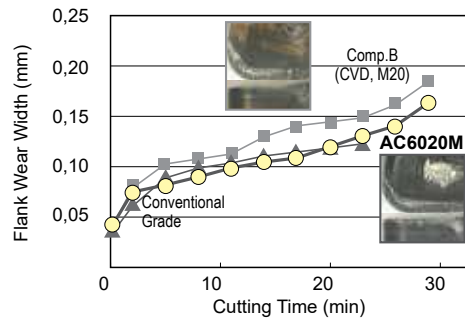

Work Material: X2CrNiMo17 13 2 Insert: CNMG 120408 NGU
 Cutting Conditions: $v_c = 200$ m/min, $f = 0,3$ mm/rev, $a_p = 2,0$ mm, wet

AC6030M

Continuous Cutting

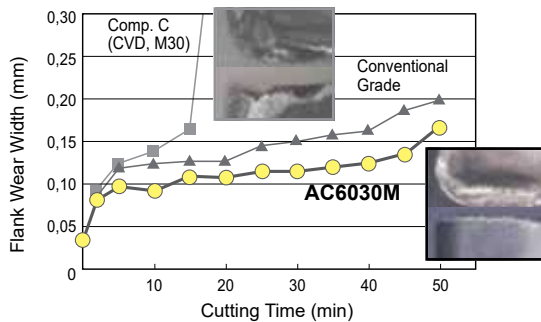

Work Material: X6CrMo17 12 2 Insert: CNMG 120408 NEX
 Cutting Conditions: $v_c = 200$ m/min, $f = 0,2$ mm/rev, $a_p = 2,0$ mm, wet

Interrupted Cutting

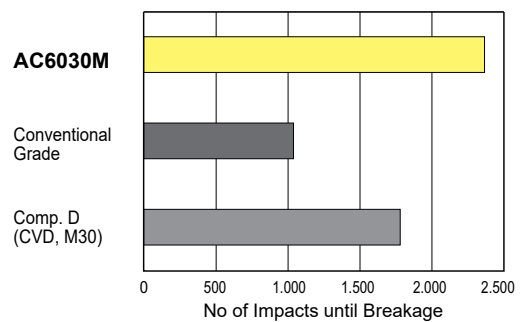

Work Material: X6CrMo17 12 2 Insert: CNMG 120408 NGU
 Cutting Conditions: $v_c = 100$ m/min, $f = 0,1$ mm/rev, $a_p = 1,0$ mm, wet

AC6040M

Continuous Cutting

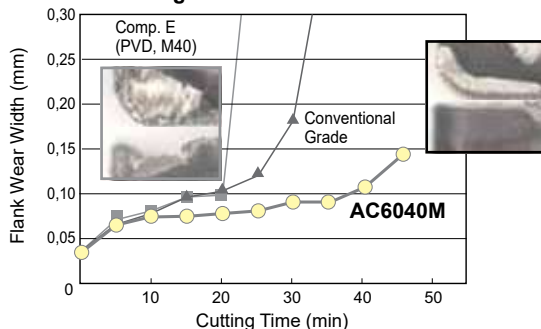

Work Material: X6CrMo17 12 2 Insert: CNMG 120408 NGU
 Cutting Conditions: $v_c = 150$ m/min, $f = 0,2$ mm/rev, $a_p = 2,0$ mm, wet

Interrupted Cutting

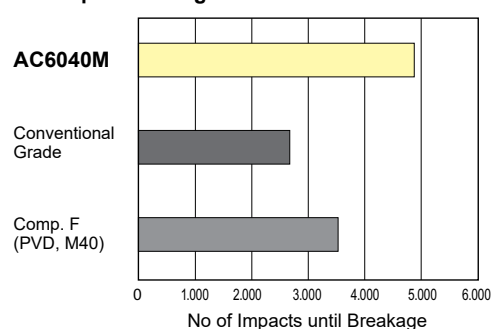

Work Material: CNMG 120408 NGU Insert: CNMG 120408 NGU
 Cutting Conditions: $v_c = 230$ m/min, $f = 0,23$ mm/rev, $a_p = 0,80$ mm, dry

Chipbreakers

Negative Type

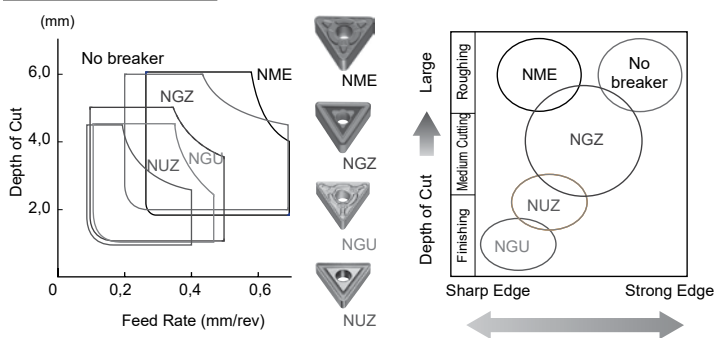

Positive Type

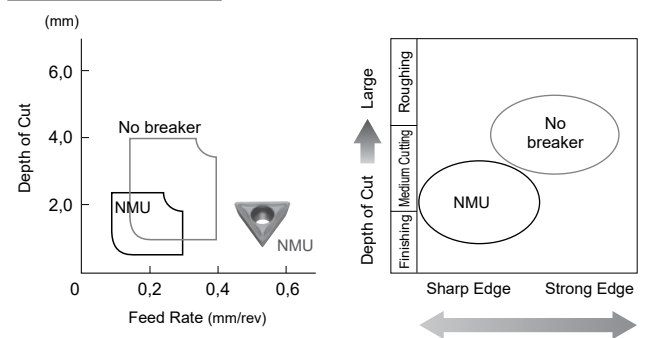

Grades

Grey Cast Iron (GG)

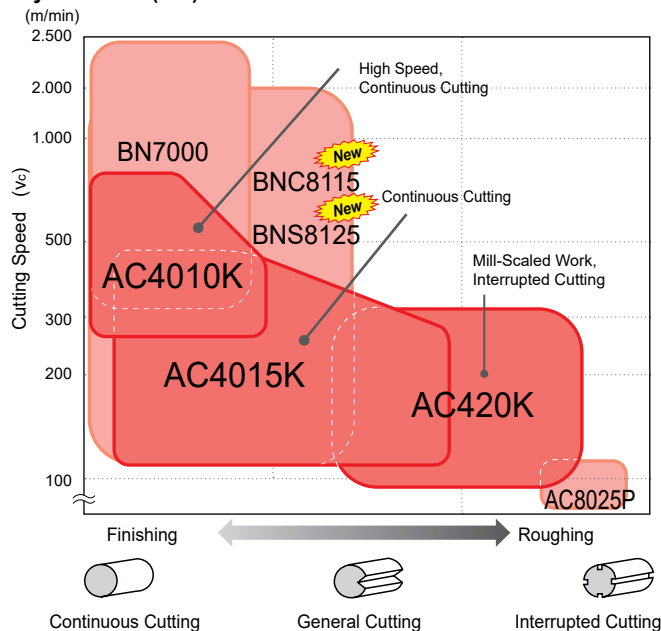

Ductile Cast Iron (GGG)

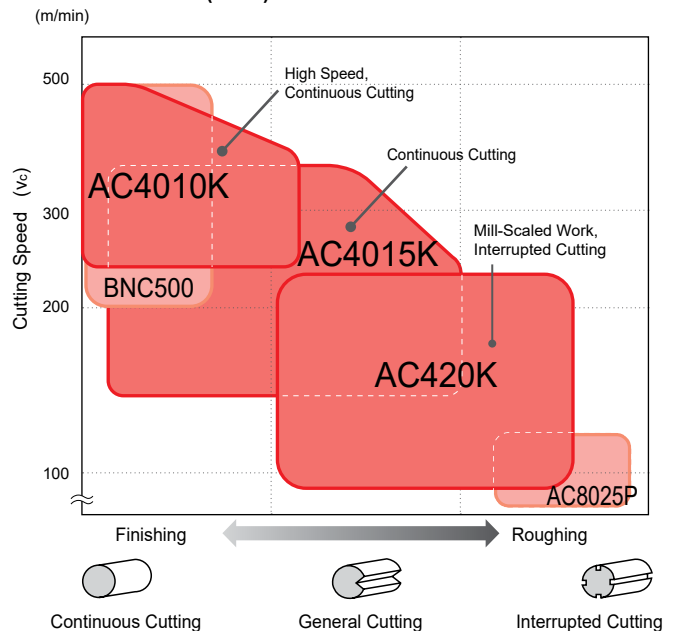

Recommended Cutting Conditions

(Min. - Optimum - Max.)

Work Materials	Cutting Process	Grades	Cutting Conditions		
			Depth of Cut a_p (mm/rev)	Feed Rate f (mm/rev)	Cutting Speed v_c (m/min)
Gray Cast Iron (GG-25, etc.)	High Speed Cutting	BN7000	0,1-0,3-1,0	0,10-0,20-0,50	500-1.500-2.000
	Continuous - General	AC4010K	0,5-2,0-6,0	0,10-0,25-0,40	200-400-700
		AC4015K	0,5-2,0-6,0	0,10-0,30-0,50	180-300-450
		AC420K	0,5-2,0-6,0	0,10-0,30-0,60	150-200-300
Ductile Cast Iron (GGG-40.3, etc.)	High Speed Cutting	BNC500	0,1-0,2-0,5	0,10-0,20-0,40	150-350-500
	Continuous - General	AC4010K	0,5-2,0-6,0	0,10-0,25-0,40	180-300-450
		AC4015K	0,5-2,0-6,0	0,10-0,30-0,50	160-250-400
		AC420K	0,5-2,0-6,0	0,10-0,30-0,60	120-170-250
High-strength Ductile Cast Iron (GGG-70, etc.)	High Speed Cutting	BNC500	0,1-0,2-0,5	0,10-0,20-0,40	200-350-500
	Continuous - General	AC4010K	0,5-2,0-6,0	0,10-0,25-0,40	160-250-400
		AC4015K	0,5-2,0-6,0	0,10-0,30-0,50	140-200-350
		AC420K	0,5-2,0-6,0	0,10-0,30-0,60	80-150-220

Grades

ABSOTECH **ABSOTECH**
AC4010K / AC4015K / AC420K

- AC4010K** The 1st recommended grade for machining grey cast iron. Adopts an ultra-thick new CVD coating to realise ultra-high-speed machining at $V_c = 700$ m/min.
- AC4015K** The 1st recommendation grade for ductile cast iron. New high-adhesion, high-strength CVD coating realises both wear resistance and chipping resistance.
- AC420K** Superior fracture resistance, providing excellent stability in interrupted unstable cutting and when cutting mill-scaled work.



Performance

AC4010K / AC4015K

Wear Resistance, Gray Cast Iron (GG)

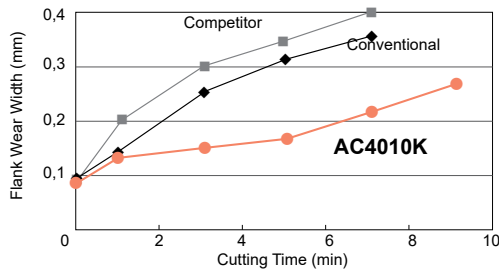

Work Material: GG-25, Continuous, Insert: CNMG120408
 Cutting Conditions: $v_c = 600$ m/min, $f = 0,4$ mm/rev, $a_p = 2,0$ mm, dry

Wear Resistance, Ductile Cast Iron (GGG)

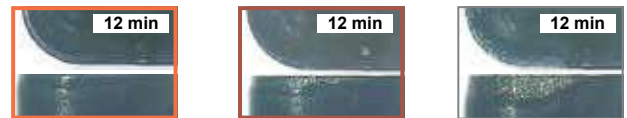
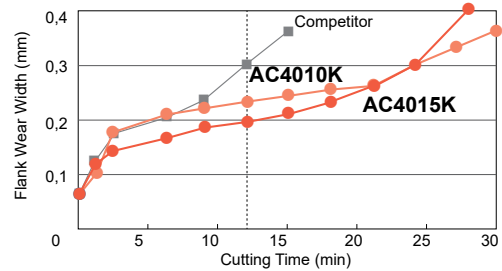

Work Material: GGG-70, Continuous, Insert: CNMG120408
 Cutting Conditions: $v_c = 140$ m/min, $f = 0,3$ mm/rev, $a_p = 1,5$ mm, wet

AC4010K / AC4015K

Chipping Resistance, Gray Cast Iron (GG)

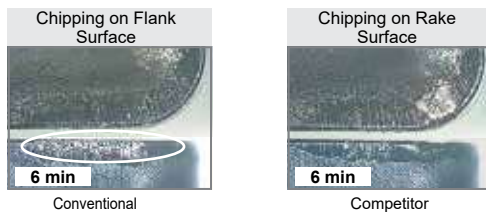
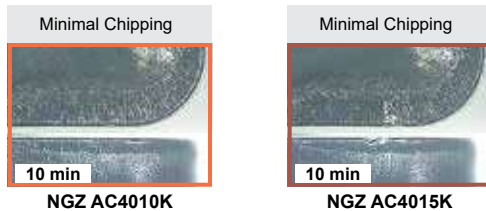

Work Material: GG-25, Interrupted, Insert: CNMG120408
 Cutting Conditions: $v_c = 400$ m/min, $f = 0,3$ mm/rev, $a_p = 2,0$ mm, wet

Chipping Resistance, Ductile Cast Iron (GGG)

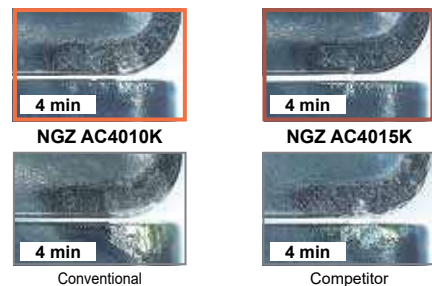
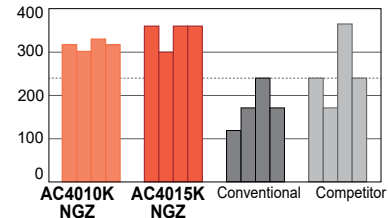

Work Material: GGG-40.3, Interrupted, Insert: CNMG120408
 Cutting Conditions: $v_c = 450$ m/min, $f = 0,3$ mm/rev, $a_p = 1,5$ mm, wet

AC420K Fracture Resistance

GGG-40.3 Grooved (Heavy Interrupted Acceleration Test)

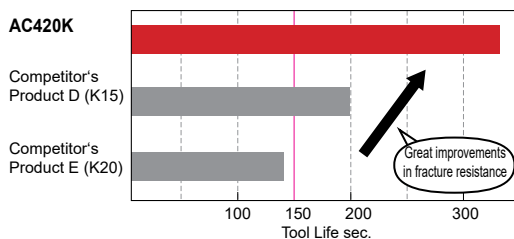

Edge Wear Comparison (After 150s)



Work Material: GGG-40.3, Toolholder: PCLNR2525-43 Insert: CNMG120408
 Cutting Conditions: $v_c = 350$ m/min, $f = 0,25$ mm/rev, $a_p = 1,5$ mm, wet

Chipbreakers

Negative Type

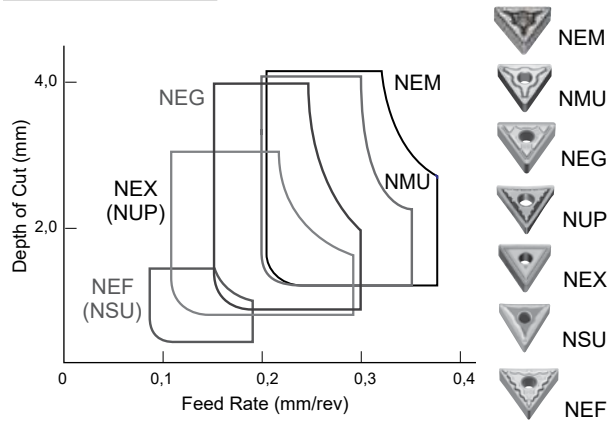

Positive Type

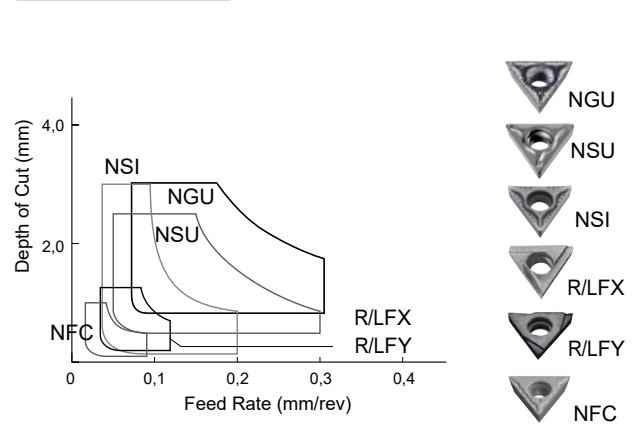

Grades

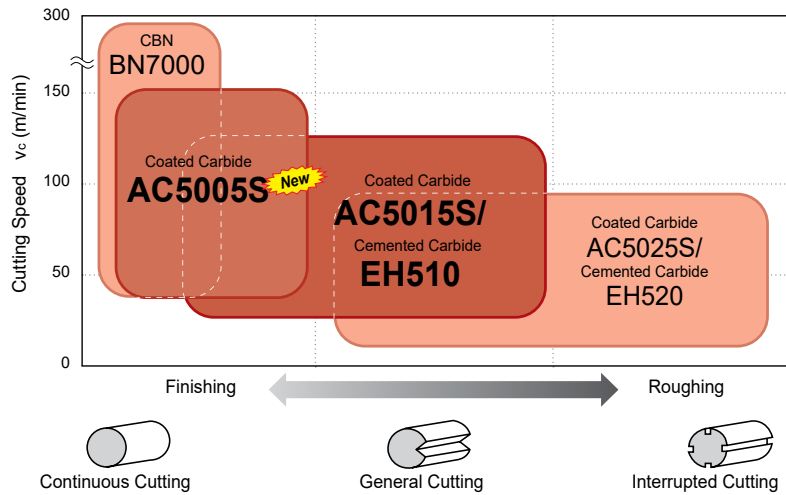

S Recommended Cutting Conditions

(Min. - Optimum - Max.)

Work Material	Cutting Process	Chipbreakers	Grades	Depth of Cut (mm)	Feed Rate (mm/rev)	Cutting Speed (m/min)
Heat-Resistant Alloy	Finishing	NEF (NSU)	AC5005S AC5015S AC5025S	0,2- 0,5 -1,5	0,10- 0,12 -0,20	50- 70 -110
	Light	NEX	AC5005S AC5015S AC5025S	0,5- 1,0 -3,0	0,10- 0,20 -0,30	40- 60 -90
	Medium	NEG	AC5005S AC5015S AC5025S	0,5- 2,0 -4,0	0,15- 0,25 -0,30	40- 60 -90
	Rough	NMU/NEM	AC5015S AC5025S	1,0- 2,0 -4,0	0,20- 0,25 -0,40	30- 55 -80
Titanium Alloy	Finishing	NEF (NSU)	EH510 (AC5005S, AC5015S)	0,2- 0,5 -1,5	0,10- 0,15 -0,20	50- 65 -80
	Light	NEX	AC5005S AC5015S	0,5- 1,0 -2,5	0,10- 0,20 -0,25	40- 55 -70
	Medium Rough	NEG	EH510 (AC5005S, AC5015S)	0,5- 2,0 -3,5	0,15- 0,25 -0,30	40- 55 -70
		NMU/NEM	AC5025S	1,0- 2,0 -3,5	0,20- 0,25 -0,30	30- 40 -50

Grades

ABSOTECH ^{New} **ABSOTECH** **ABSOTECH**
AC5005S / AC5015S / AC5025S / EH510 / EH520

PVD grade with excellent wear and thermal resistance.

AC5005S High-speed, high-efficiency grade with great high-temperature strength, which realises excellent wear resistance in high-efficiency machining.

AC5015S The 1st recommended grade for turning exotic alloys as it realises stable tool life with high-speed, high-efficiency machining.

AC5025S High-toughness grade for realising stable tool life for interrupted cutting machining or mill-scaled work.

Carbides with excellent thermal, wear, and fracture resistance for use with exotic alloys. Lineup also includes new chipbreaker design.

EH510 General purpose grade for titanium machining that features excellent wear and thermal resistance. For applications from roughing to finishing.

EH520 Tough grade for titanium machining with excellent fracture and thermal resistance. Perfect for interrupted cutting and mill-scaled work.

Performance

AC5005S

Wear Resistance (High-speed)

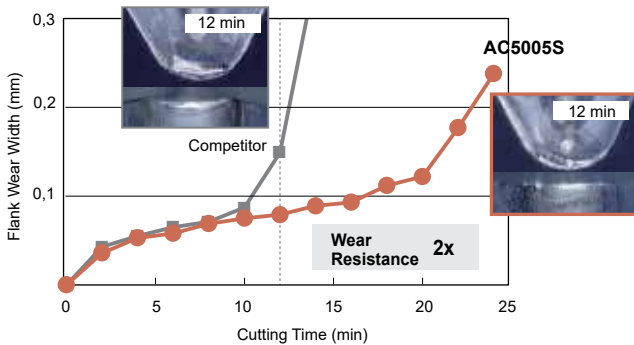

Work Material: Inconel 718 (44 HRC) Insert: DNMG150408 NEF
 Cutting Conditions: $v_c = 100$ m/min, $f = 0,15$ mm/rev, $a_p = 0,5$ mm, wet

Wear Resistance (High-feed)

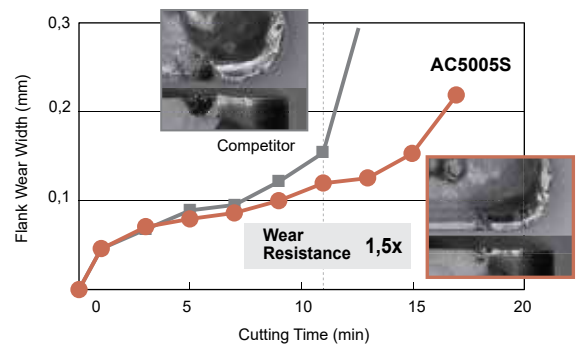

Work Material: Inconel 718 (44 HRC) Insert: CNMG120408 NEG
 Cutting Conditions: $v_c = 50$ m/min, $f = 0,25$ mm/rev, $a_p = 1,2$ mm, wet

AC5015S

Wear Resistance

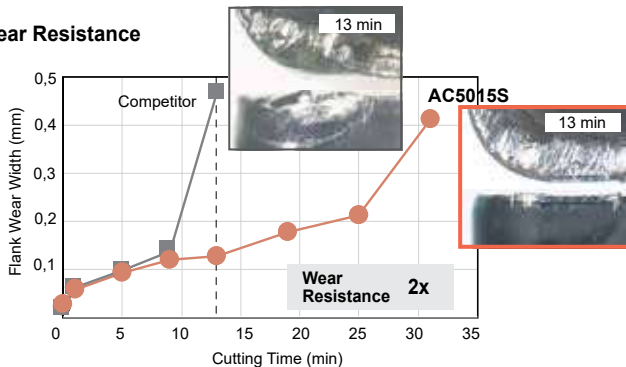

Work Material: Inconel 718 (44 HRC) Insert: CNMG120408 NEX
 Cutting Conditions: $v_c = 40$ m/min, $f = 0,1$ mm/rev, $a_p = 1,5$ mm, wet

Fracture Resistance

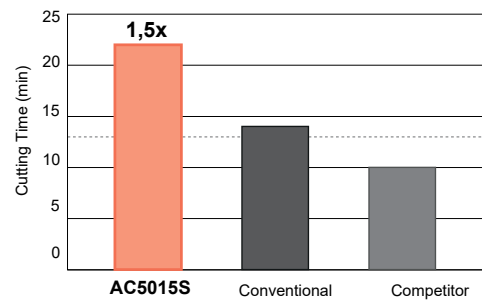

Work Material: Hastelloy (22 HRC), Insert: CNMG120408 NEX
 Cutting Conditions: $v_c = 50$ m/min, $f = 0,1$ mm/rev, $a_p = 1,5$ mm, wet

AC5025S

Wear Resistance

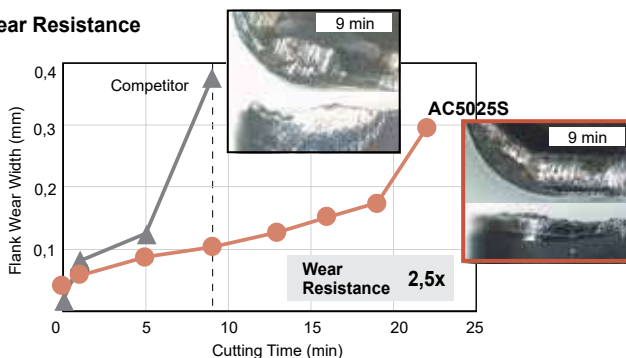

Work Material: Inconel 718 (44 HRC) Insert: CNMG120408 NEX
 Cutting Conditions: $v_c = 40$ m/min, $f = 0,1$ mm/rev, $a_p = 1,5$ mm, wet

Fracture Resistance

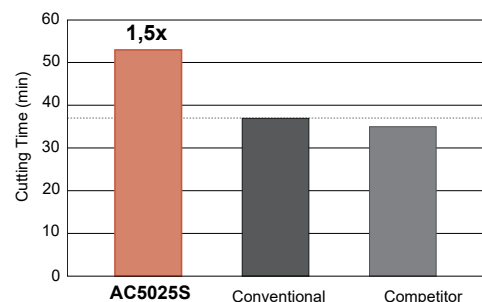

Work Material: Hastelloy (22 HRC), Insert: CNMG120408 NEX
 Cutting Conditions: $v_c = 50$ m/min, $f = 0,1$ mm/rev, $a_p = 1,5$ mm, wet

Chipbreakers

NSV Type Chipbreaker: For chip control during carburized layer removal

NLV Type / NFV Type Chipbreaker: For chip control during finishing of hardened steel

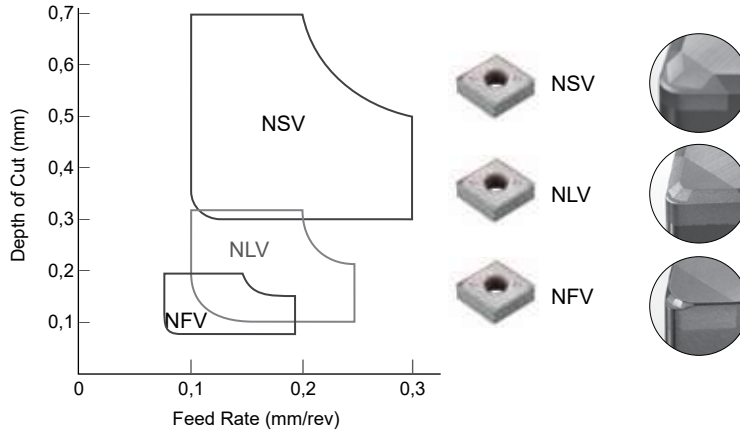

Grades

Coated SUMIBORON

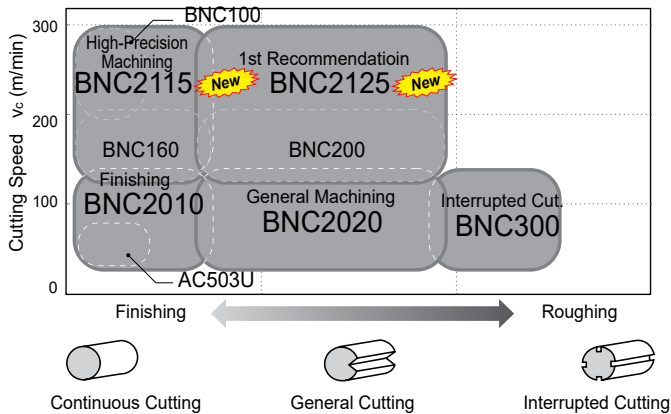

Uncoated SUMIBORON

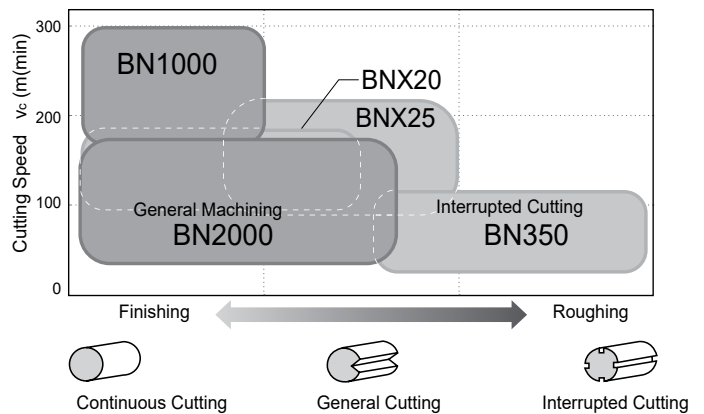

H Recommended Cutting Conditions

(Min. - Optimum - Max.)

Cutting Process	Grade	Depth of Cut (mm)	Feed Rate (mm/rev)	Cutting Speed (m/min)
Continuous Cutting	BNC2115	0,03- 0,20 -0,35	0,03- 0,10 -0,20	110- 180 -300
	BNC2010	0,03- 0,20 -0,35	0,03- 0,10 -0,20	50- 140 -180
	BNC100	0,03- 0,15 -0,20	0,03- 0,10 -0,20	80- 200 -300
	BN1000	0,03- 0,15 -0,20	0,03- 0,10 -0,15	120- 180 -300
	AC503U	0,03- 0,50 -1,00	0,02- 0,05 -0,10	40- 70 -100
General Turning	BNC2125	0,05- 0,30 -0,50	0,05- 0,20 -0,40	110- 160 -300
	BNC2020	0,05- 0,30 -0,50	0,03- 0,20 -0,40	50- 120 -180
	BNC160	0,03- 0,20 -0,35	0,03- 0,10 -0,20	80- 160 -270
	BNC200	0,03- 0,30 -0,50	0,05- 0,10 -0,35	80- 140 -270
	BN2000	0,03- 0,20 -0,30	0,03- 0,10 -0,20	30- 100 -200
	BNX20	0,03- 0,30 -0,50	0,03- 0,15 -0,30	70- 130 -170
Interrupted Cutting	BNC300	0,03- 0,20 -0,30	0,03- 0,10 -0,20	50- 100 -150
	BN350	0,03- 0,20 -0,30	0,03- 0,10 -0,20	50- 100 -150
	BNX25	0,03- 0,20 -0,50	0,03- 0,15 -0,30	120- 160 -220

Grades

BNC2115 / BNC2125 / BN1000 / BN2000

- BNC2115** New
High-precision grade realizing long tool life with excellent surface roughness and stable machining. Maintains excellent surface roughness thanks to a high notch-wear resistant coating and tough CBN substrate.

- BNC2125** New
1st recommendation grade, balancing excellent wear resistance and fracture resistance in hardened steel machining. Along with a tough CBN substrate, the coating combines wear resistance and toughness to achieve long, stable tool life even in high-efficiency and interrupted machining.

- BN1000**
For high speed machining. BN1000 provides the highest wear resistance of all uncoated SUMIBORON grades. Features improved fracture resistance while still placing a priority on wear resistance.

- BN2000**
General purpose grade suitable for typical hardened steel machining applications. Provides a high degree of fracture and wear resistance.

Performance

BNC2115

Continuous Cutting of Hardened Steel

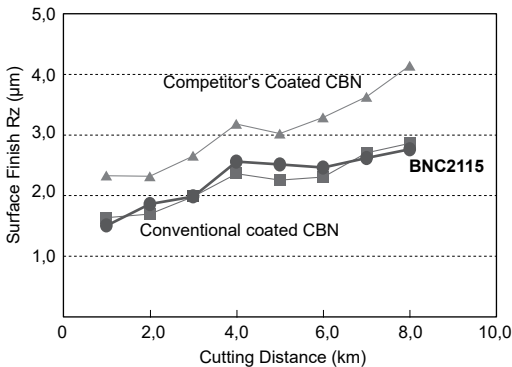

Work Material: SCM415H, 58-62HRC
 Insert: DNGA 150408 NC4
 Cutting Conditions: $v_c = 200$ m/min, $f = 0,1$ mm/rev, $a_p = 0,15$ mm, wet

BNC2125

Interrupted Cutting of Hardened Steel

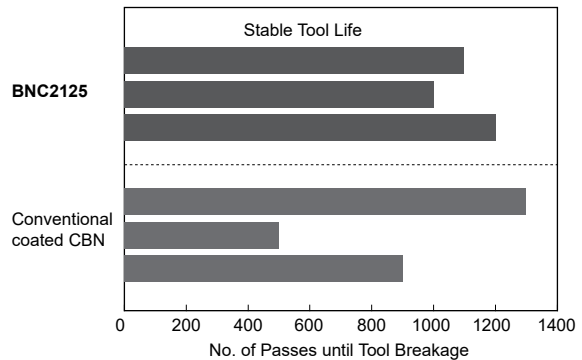

Work Material: SUJ2, 58-62HRC
 Insert: DNGA 150408 NC4 S01225
 Cutting Conditions: $v_c = 150$ m/min, $f = 0,15$ mm/rev, $a_p = 0,5$ mm, 63 m/times, dry

BN1000 / BN2000

Wear Resistance (Continuous Cutting)

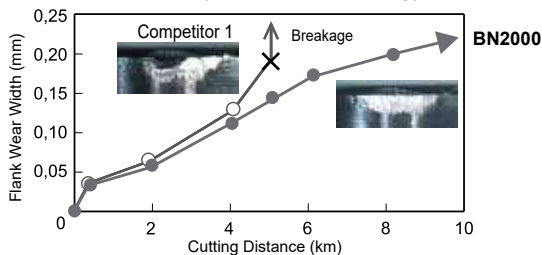

Work Material: 15CrMo5, Round Bar (58-62HRC)
 Cutting Conditions: $v_c = 100$ m/min, $f = 0,1$ mm/rev, $a_p = 0,2$ mm, dry

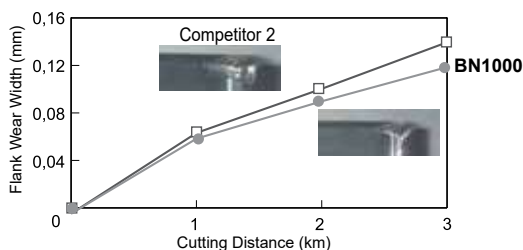

Work Material: 100Cr6, Round Bar (58-62HRC)
 Cutting Conditions: $v_c = 150$ m/min, $f = 0,1$ mm/rev, $a_p = 0,2$ mm, dry

Chipping Resistance (Interrupted Cutting)

(Comparison based on conventional BN2000 as 100%.)

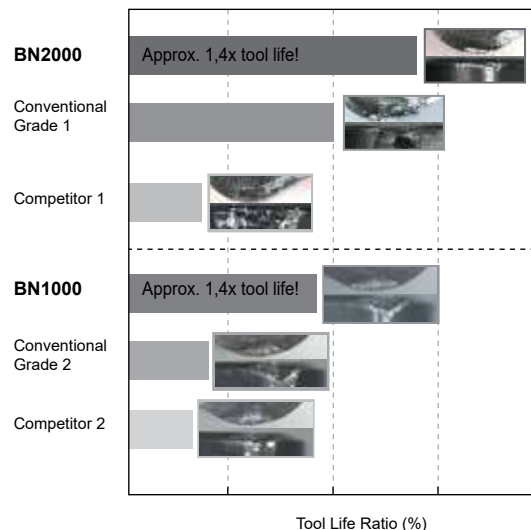

Work Material: 15CrMo5, 8V Grooved Material (58-62HRC)
 Insert: CNGA120408 NU-2
 Cutting Conditions: $v_c = 150$ m/min, $f = 0,1$ mm/rev, $a_p = 0,2$ mm, dry

Chipbreakers

Negative Type

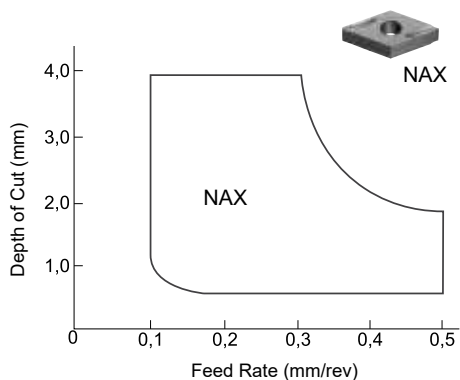

Positive Type

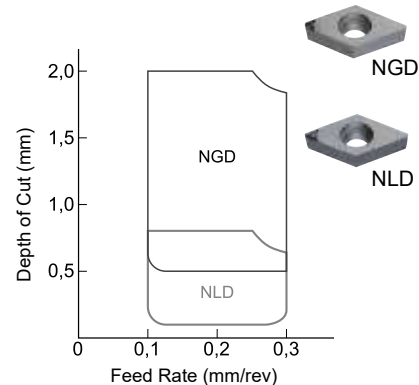
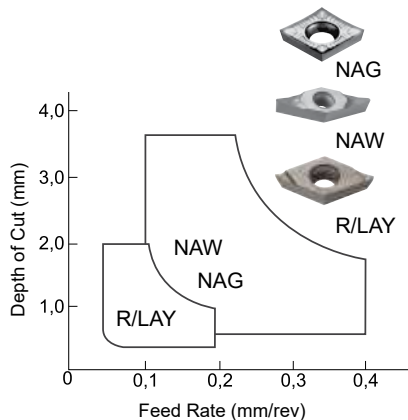

Grades

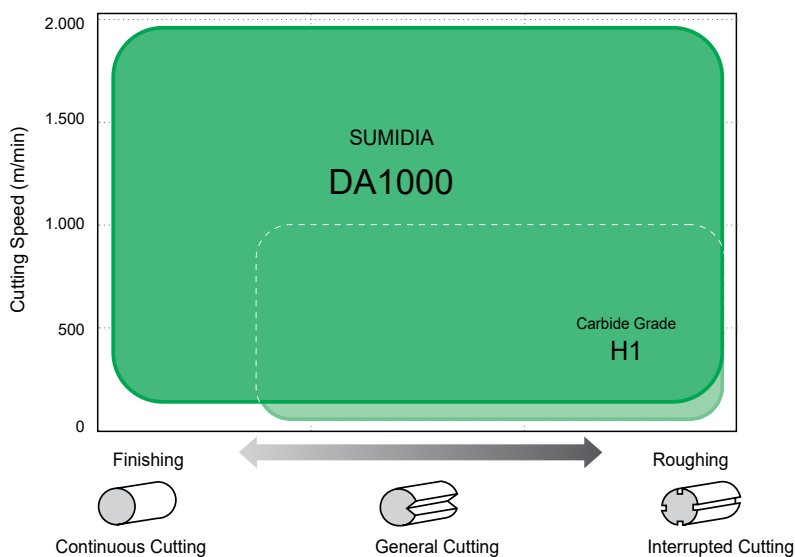

N Recommended Cutting Conditions

(Min. - Optimum - Max.)

Cutting Process	Category	Grades	Cutting Conditions		
			Depth of Cut (mm)	Feed Rate (mm/rev)	Cutting Speed (m/min)
Continuous Cutting General Turning Interrupted Cutting	SUMIDIA	DA1000	0,1- 0,5 -3,0	0,05- 0,10 -0,20	-2000
	Carbide	H1	0,3- 1,0 -5,0	0,1- 0,20 -0,5	-1000

Grades

DA1000

- Ultra-high-density sintered, ultra-fine diamond particles
- Significantly improved surface roughness on machined surfaces
- World's best wear resistance and strength
- Suitable for use with all aluminium and non-ferrous alloys

DA1000 Wear Resistance

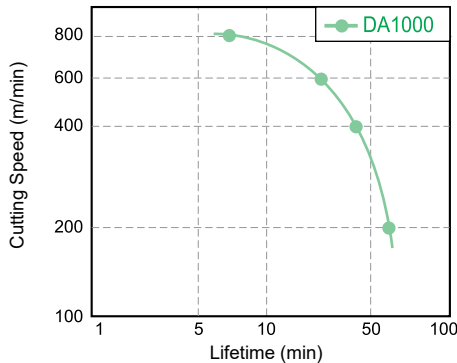

Comparison of Surface Roughness of Nose Radius Cutting Edge

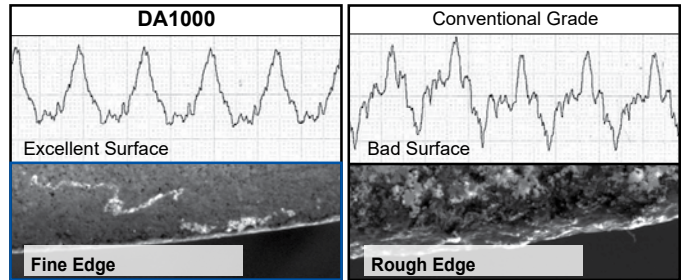

Insert: TPGW 160308
Cutting Conditions: $v_c = 1000$ m/min, $f = 0,15$ mm/rev, $a_p = 0,2$ mm, Wet

Wear Resistance in Turning Applications

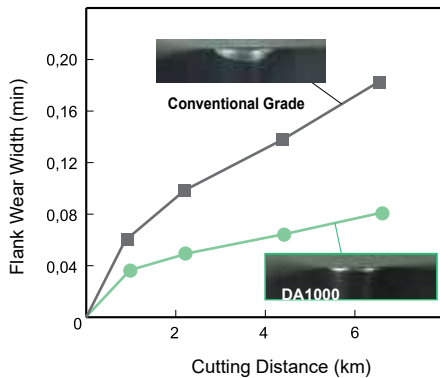

Insert: TPGN160304
Cutting Conditions: $v_c = 800$ m/min, $f = 0,12$ mm/rev, $a_p = 0,5$ mm, wet

Wear Resistance in Milling Applications

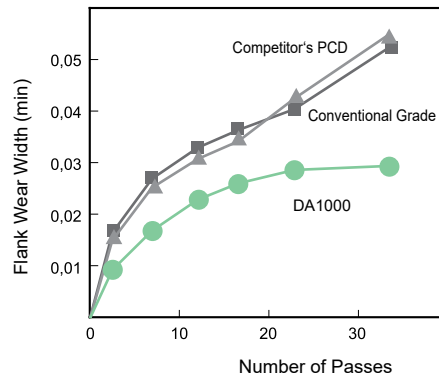

Insert: SNEW1204 ADRF-NF
Cutting Conditions: $v_c = 2000$ m/min, $f = 0,15$ mm/rev, $a_p = 3,0$ mm, wet

Application Examples

H1 + NAG Type Breakers

ADC12 Aluminium Wheel

Excellent adhesion resistance.
Longer tool life.

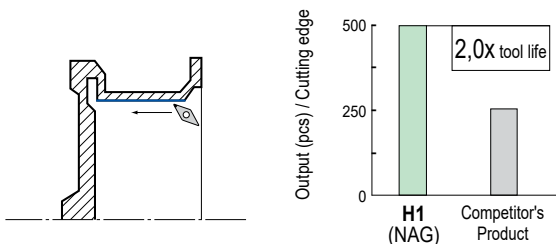

Insert: VCGT160408 NAG (H1)
Cutting Conditions: $v_c = 2000$ m/min, $f = 0,25$ mm/rev, $a_p = 2,0$ mm, wet

DA1000

Copper Alloy Bush

Stable surface roughness with no edge breakage (3,2S).
Tool life improved to 3x that of conventional models.

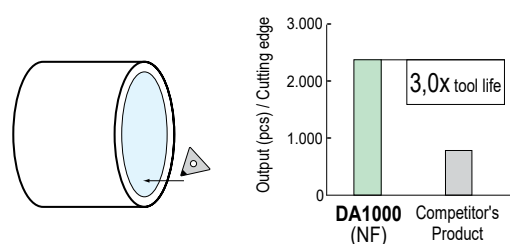

Insert: TPGN160308 NF (DA1000)
Cutting Conditions: $v_c = 300$ m/min, $f = 0,07$ mm/rev, $a_p = 0,08$ mm, wet

Grades

Category	Application Range			Work Material					
	High Precision	Finish-Light Cut	Medium Cut	P General Steel	M Stainless Steel	K Cast Iron	S Heat Resistant Steel	H Hardened Steel	N Non-Ferrous Metal
Coated Carbide (PVD)	ACZ150			◎	◎				○
	AC5015S			○	◎				
	AC5025S			○	◎	○			
	AC530U			○	◎	○	◎		○
	AC1030U			○	◎	○	○		○
Cermet/Coated Cermet	T1000A			◎	○	◎			○
	T1500A/T1500Z			◎	○	○			○
Carbide	H1			○	○	○			◎
	EH510			○	○	○	◎		○
CBN (SUMIBORON)	BN1000/BN2000							◎	
	BN7000							◎	
SUMIDIA	DA1000								◎

◎ Preferred Choice ○ Suitable

Chipbreakers

M-Class Finishing to Light Cut

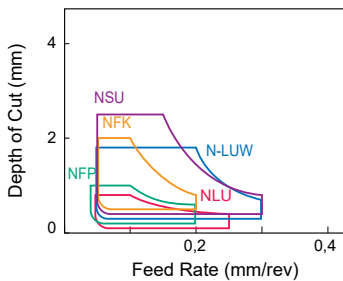

G-Class Chipbreaker (Groove Design)

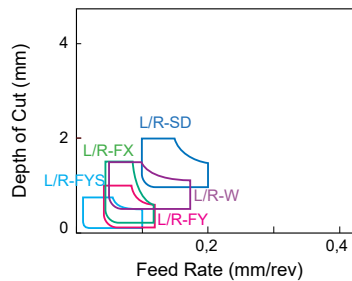

G-Class Chipbreaker (3D Design)

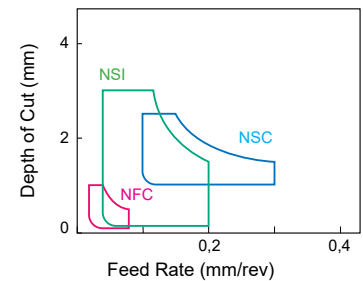

Recommended Cutting Conditions

Grade	P Free Cutting Steel		P Carbon Steel		M Stainless Steel		S Heat Resistant Steel		H Hardened Steel		N Aluminium		N Brass	
	v _c (m/min)	f (mm/rev)	v _c (m/min)	f (mm/rev)	v _c (m/min)	f (mm/rev)	v _c (m/min)	f (mm/rev)	v _c (m/min)	f (mm/rev)	v _c (m/min)	f (mm/rev)	v _c (m/min)	f (mm/rev)
ACZ150	50-200	0,02-0,10	50-150	0,01-0,08	50-150	0,01-0,05					70-300	0,05-0,20	70-300	0,05-0,20
AC5015S	50-200	0,02-0,15	50-200	0,02-0,10	50-200	0,02-0,10	30-100	0,02-0,10					70-300	0,05-0,20
AC5 25S	50-200	0,02-0,15	50-200	0,02-0,10	50-200	0,02-0,10	30-100	0,02-0,10					70-300	0,05-0,20
AC530U	50-200	0,02-0,15	50-200	0,02-0,10	50-200	0,02-0,10							70-300	0,05-0,20
AC1030U	50-200	0,02-0,15	50-200	0,02-0,10	50-150	0,02-0,10							70-300	0,05-0,20
T1000A	50-200	0,02-0,15	50-200	0,02-0,10	50-150	0,02-0,10					70-300	0,05-0,20	70-300	0,05-0,20
T1500A	50-200	0,02-0,15	50-200	0,02-0,10	50-150	0,02-0,10					70-300	0,05-0,20	70-300	0,05-0,20
T1500Z	50-200	0,02-0,15	50-200	0,02-0,10	50-150	0,02-0,10					70-300	0,05-0,20	70-300	0,05-0,20
BN1000									120-300	0,03-0,15				
BN2000									50-200	0,03-0,20				
BN7000							50-200	0,05-0,20						
DA1000											70-300	0,02-0,10	70-300	0,02-0,10

Application Range

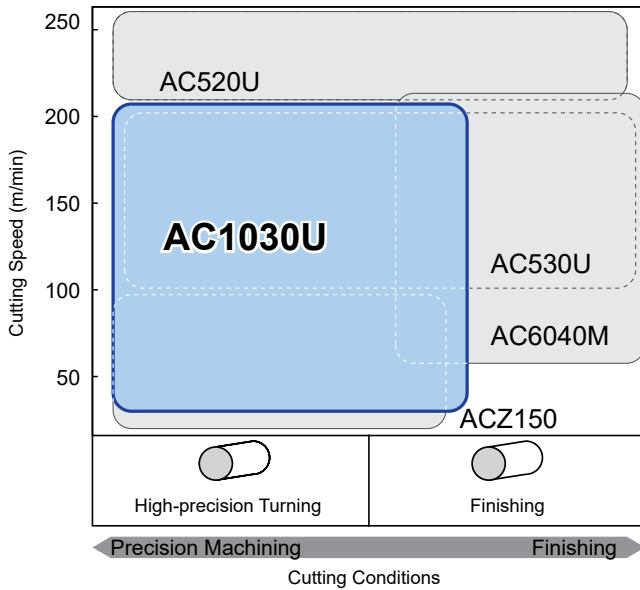

ABSOTECH AC1030U

Employs a new PVD coating, with a special tough carbide substate. Achieving excellent machined surface quality with a high-quality cutting edge that reduces adhesion and micro-chipping.

AC1030U Performance

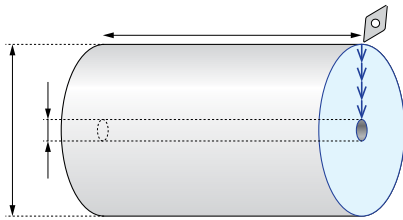

Material: X5CrNiS18-10, 1.4301
 Insert: DCGT11T302RFY (AC1030U)
 Cutting Data: $v_c = 100$ m/min, $f = 0,05$ mm/rev, $a_p = 0,1$ mm, wet (Oil)

Wear Resistance

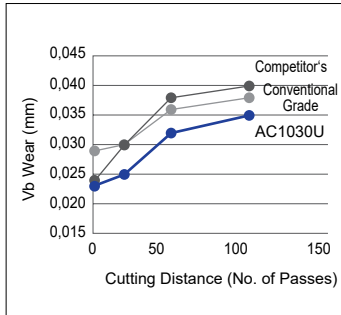

Roughness

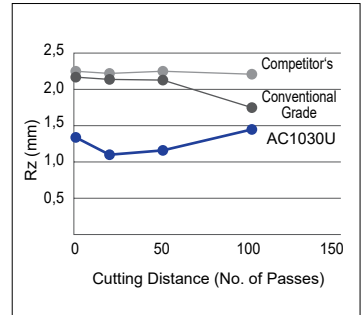

Application Examples

STKM12C-EC, Pipe

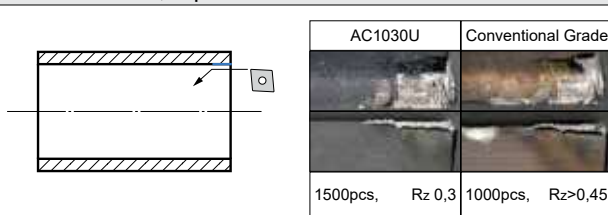

Insert: CCGT060201LFX (AC1030U)
 Cutting Data: $v_c = 196$ m/min, $f = 0,04$ mm/rev, $a_p = 0,4$ mm, wet

C45, Stator Shaft

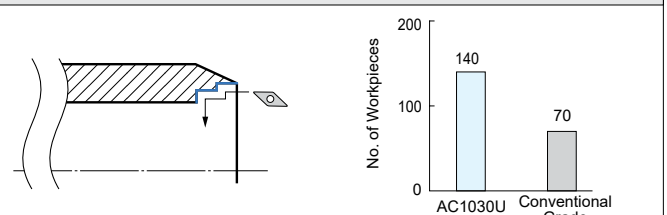

Insert: VCGT110302RFX (AC1030U)
 Cutting Data: $v_c = 195$ m/min, $f = 0,12$ mm/rev, $a_p = 0,175-0,25$ mm, wet

X5CrNiS18-10, 1.4301, Valve Body

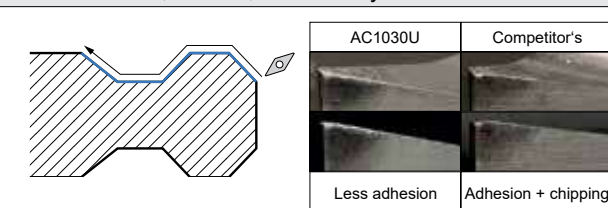

Insert: VCGT110301RFY (AC1030U)
 Cutting Data: $v_c = 31,5$ m/min, $f = 0,025$ mm/rev, $a_p = 0,2$ mm, wet

X6Cr17, Sensor Housing

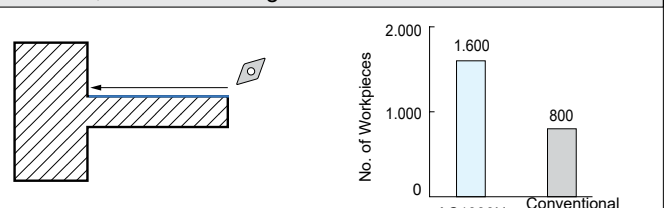

Insert: DCGT11T304M NFC (AC1030U)
 Cutting Data: $v_c = 50$ m/min, $f = 0,06$ mm/rev, $a_p = 0,2$ mm, wet

New Grades for Milling

New **New**
ACU2500 / XCU2500 / XCK2000

Insert Selection

Features of ACU2500

- Utilizing ABSOTECH, a new coating with excellent wear and chipping resistance.
- Adopts a carbide substrate with excellent fracture resistance and wear resistance, realising stable long tool life with various work material grades. Our 1st recommended grade for milling.

Features of XCU2500 / XCK2000

- Uses the revolutionary ABSOTECH X coating, combining the wear resistance of conventional CVD coatings and fracture resistance equivalent to that of PVD coatings.
- Superb long tool life in machining of steel, cast iron, and stainless steel.

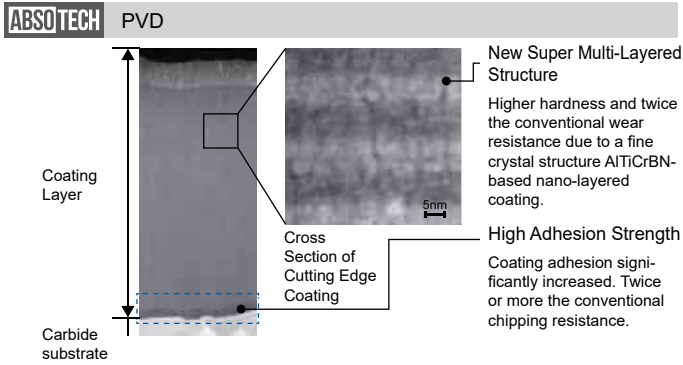

Applicable Grades: ACU2500, ACP3000, ACK3000

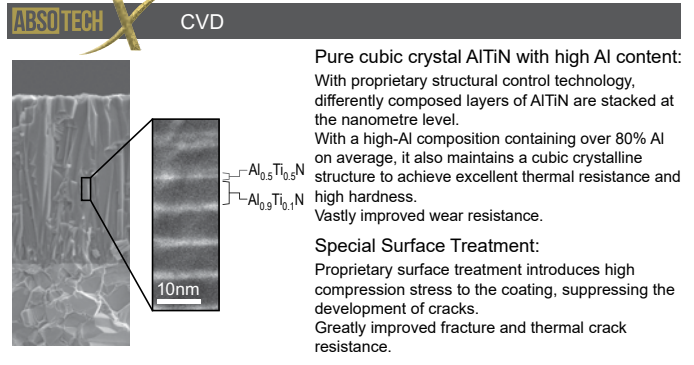

Applicable Grades: XCU2500, XCK2000

Application Range

P Steel

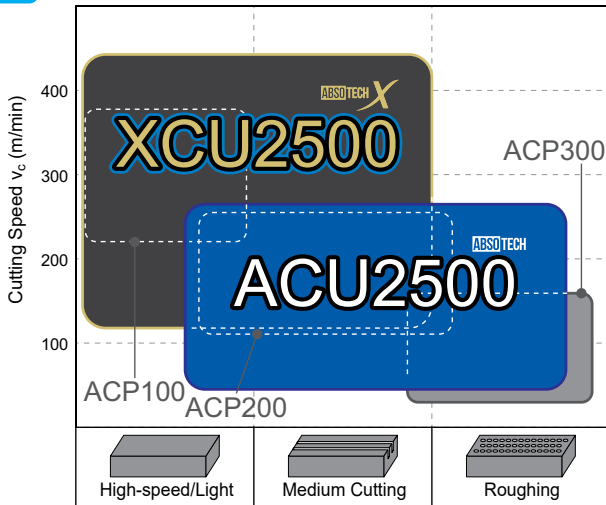

M Stainless Steel

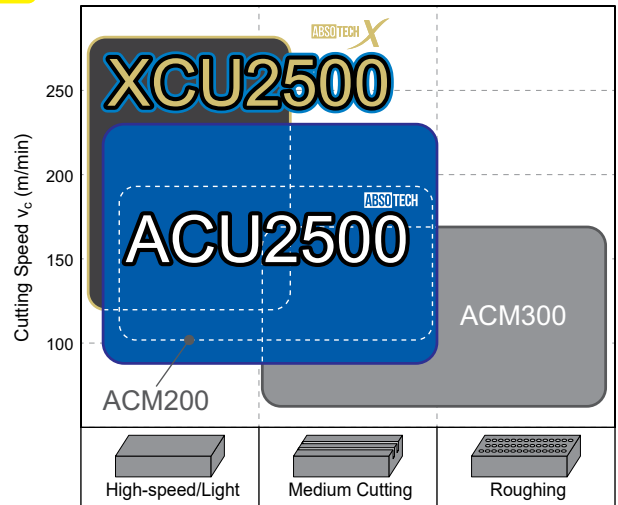

K Cast Iron

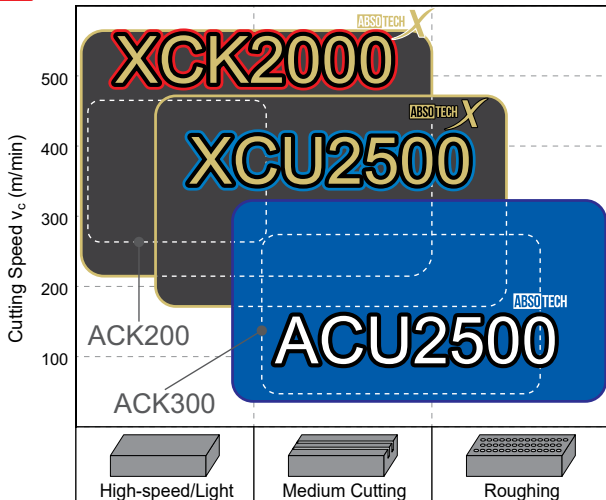

S Exotic Alloy

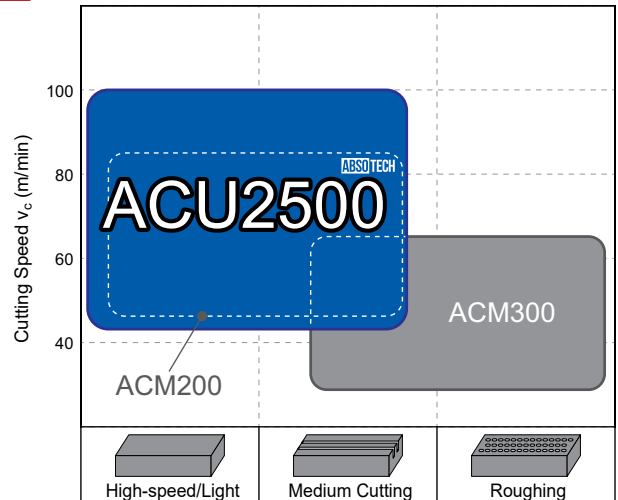

Grades

B

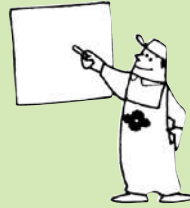

B1–B14



Grades

Coated Grades	Coating Series	B2
	CVD / PVD Series	B3–4
Coated and Uncoated	Cermet	B5
Uncoated Carbide	“Igetalloy”	B6
CBN Grades	“SUMIBORON”	B7–8
PCD Grades	“SUMIDIA”	B9
	“SUMIDIA” Binderless	B10
Chart	Grades Comparison Chart	B11–14

Coated Carbide

ABSOTECH X : Revolutionary coating technology that realises superb tool life.

CVD

Pure cubic crystal AlTiN with high Al content:
With proprietary structural control technology, differently composed layers of AlTiN are stacked at the nanometre level. With a high-Al composition containing over 80% Al on average, it also maintains a cubic crystalline structure to achieve excellent thermal resistance and high hardness. Vastly improved wear resistance.

Special Surface Treatment:
Proprietary surface treatment introduces high compression stress to the coating, suppressing the development of cracks. Greatly improved fracture and thermal crack resistance.

Realises extremely long tool life for general machining through high-efficiency machining, using revolutionary technology combining wear resistance and fracture resistance.

[ABSOTECH X] For CVD Milling
Applicable Grades
For Milling: **XCU2500, XCK2000**

ABSOTECH : New coating technology that realises absolute stability.

CVD

Special Surface Treatment:
Chipping resistance and adhesion resistance are significantly improved by special surface treatment applied to suit the application.

High Strength Alumina Layer:
Significantly improves the coating strength by controlling crystal growth direction.

High Hardness Micro-Grain TiCN Layer:
Significantly improves the coating hardness by using a fine and uniform crystal structure.

High Adhesion Technology:
Significantly improves adhesion strength through a smooth interface between the coating and carbide substrate.

- Suppresses abnormal damage such as chipping and adhesion. Stable machining is achieved in various situations.
- Next-level high strength and high hardness coating is achieved. Achieves long, stable tool life even in high-efficiency machining.

PVD

The Proprietary Super Multi-layered Coating Structure:
Advanced nanotechnology enables nanometre level thickness (1 nanometre is one billionth of a meter). Hardness, thermal resistance and toughness are significantly improved by alternately layering one thousand layers of super thin films.

High Adhesion Technology:
Significantly improves adhesion strength through advanced control technology at the interface of the coating and carbide substrate.

- Optimised coating composition according to application. Achieves stable machining regardless of the work material.
- Significantly improves chipping resistance by improving coating adhesion strength. Stable machining is realised even under high load conditions.

Applicable Grades
For Turning: Steel AC8015P, AC8020P, AC8025P, AC8035P
Stainless Steel AC6020M, AC6030M
Cast Iron AC4010K, AC4015K
For Milling: ACP2000, ACK2000

Applicable Grades
For Turning: Stainless Steel AC6040M
Exotic Alloy AC5005S, AC5015S, AC5025S
Small Lathes AC1030U
For Milling: **ACU2500, ACP3000, ACK3000**

Brilliant Coat **PVD**

Brilliant Coat provides excellent lubricity for higher quality machining.

- PVD coating with excellent wear resistance and lubricity.
- Suppresses reactions with work material and realises beautiful machined surfaces.

Work Material: STKM13A
Insert: CNMG120408NLU
Cutting Conditions: v_c: 100 m/min
f: 0,15 mm/rev
a_p: 1,0 mm, wet

Applicable Grades
For steel turning T1500Z, T2500Z

AURORA Coat (DLC : Diamond Like Carbon) **PVD**

Using our proprietary PVD process technology, we have developed a hydrogen-free DLC coating that is extremely hard and smooth.

Comparison of Cutting Edge Adhesion After Cutting ADC12

Work Material: STKM13A
Cutting Conditions: v_c: 100 m/min
f: 0,15 mm/rev
a_p: 1,0 mm, wet

- Second only to diamond in terms of hardness, this smooth coating has a low coefficient of friction and provides excellent adhesion resistance to deliver better-quality machined surfaces.
- Can be used for high-speed, high-efficiency cutting of aluminium alloys, copper alloys, resins, and more.

Applicable Grades
For Milling DL1000, DL2000
For Endmilling DL1000, DL1200
For Drilling DL1300, DL1500

Characteristic Values

For Turning (CVD)

Class	Grade	Hardness (HRA)	TRS (GPa)	Coating Type	Coating Thickness (µm)	Characteristics	Old Grades
P	AC8015P	91,0	2,3	Absotech	14	For high-speed and high-efficiency machining of steel. Crystal orientation control technology is used to drastically suppress the advancement of crater wear, achieving long, stable tool life during high-speed and high-feed cutting.	AC810P
	New AC8020P	90,5	2,2	Absotech	18	Our 1st recommended grade for mill-scale work on forged material. Alumina coating with even higher strength balances outstanding stability and wear resistance in mill-scale work.	AC820P
	AC8025P	90,1	2,3	Absotech	12	A P20 grade that drastically reduces the occurrence of abnormal damage and achieves long and stable tool life by employing a special carbide substrate and the new Absotech Platinum coating.	AC820P
	AC8035P	89,4	2,6	Absotech	9	For interrupted machining of steel. Coating layer tensile stress removal technology greatly improves fracture resistance and achieves long, stable tool life during heavy interrupted cutting.	AC830P
M	AC6020M	90,1	2,3	Absotech	5	An M20 grade that maintains wear resistance in stainless steel machining while drastically reducing the occurrence of abnormal damage by employing a special carbide substrate and the new Absotech Platinum coating.	AC610M
	AC6030M	89,5	2,7	Absotech	5	The first recommended grade for general machining of stainless steel that drastically reduces the occurrence of abnormal damage in stainless steel machining and achieves long and stable tool life by employing a new coating: Absotech Platinum.	AC630M
	AC630M	89,5	2,7	Super FF Coat	5	A general purpose grade featuring improved wear and fracture resistance during stainless steel cutting. Utilises a special tough carbide substrate with a thin Super FF Coat.	AC304
K	AC4010K	91,1	2,5	Absotech	20	1st recommended grade for turning grey cast iron. For high-speed cast iron milling. New thick coating realizes stable long tool life even with ultra-high-speed machining of grey cast iron at $v_c = 700$ m/min.	AC405K
	AC4015K	91,1	2,5	Absotech	16	1st recommended grade for turning ductile cast iron. New high-adhesion, high-strength coating realises high wear resistance and chipping resistance for stable long tool life over a wide range of cutting conditions.	AC415K
	AC420K	91,1	2,5	Super FF Coat	12	A new, extremely versatile grade that can be used for rough, interrupted cutting of ductile and grey cast iron. Employs special, ultra-hard carbide substrate and Super FF Coat to provide stability and long tool life.	AC700G

For Milling (CVD)

Class	Grade	Hardness (HRA)	TRS (GPa)	Coating Type	Coating Thickness (µm)	Characteristics	Old Grades
P	ACP100	89,3	3,1	Super FF Coat	6	A grade that employs a tough carbide substrate and thin-layer Super FF Coat to provide superior thermal crack and wear resistance in high-speed milling of steel.	AC230
	ACP2000	89,5	3,2	Absotech	10	For high-speed machining of steel. Stable long tool life with high-speed machining is realized by adopting a tough carbide substrate and a new coating with excellent thermal crack resistance.	ACP100
	New XCU2500	89,5	3,2	AbsotechX	6	General purpose grade for a wide variety of materials such as steel, cast iron and stainless steel. New coating combining wear and fracture resistance realises long tool life in medium-speed to high-speed machining.	
M	ACM200	89,8	3,4	Super FF Coat	6	A grade ideal for hardened steel machining that provides excellent wear and heat resistance by employing a newly-developed ultra-hard carbide and Super FF Coat.	AC230
K	ACK100	92,0	2,4	Super FF Coat	6	A grade that employs a high-strength carbide substrate and Super FF Coat to provide excellent wear resistance in high-speed milling.	—
	ACK200	91,7	2,5	Super FF Coat	6	A grade that employs a tough carbide substrate and thin-layer Super FF Coat to provide superior thermal crack and wear resistance for high-speed milling.	AC211
	ACK2000	91,7	3,1	Absotech	10	For high-speed cast iron milling. Stable long tool life with high-speed machining is realized by adopting a tough carbide substrate and a new coating with excellent thermal resistance.	ACK100 ACK200
	New XCK2000	91,7	2,5	AbsotechX	6	For high-speed cast iron milling. Along with a high-hardness carbide substrate, the new coating combining wear and fracture resistance realises superb long tool life in medium-speed to high-speed machining.	—

Characteristic Values

For Turning (PVD)

Class	Grade	Hardness (HRA)	TRS (GPa)	Coating Type	Coating Thickness (µm)	Characteristics	Old Grades
P	T1500Z (Cermets)	92,0	2,2	Brilliant Coat*	3	For finishing of steel. Adopts Brilliant Coat for excellent lubricity and higher machined surface quality.	T2000Z
	T2500Z (Cermets)	91,8	2,4	Brilliant Coat*	3	For finishing of steel. The use of Brilliant Coat with excellent lubricity and a tough cermet substrate realises excellent machined surface quality and superb stability.	T3000Z
	AC530U	91,4	3,3	Super ZX Coat	3	For interrupted and general steel cutting. Utilizing the super multi-layered PVD coating of nanometre thick TiAlN and AlCrN layers, coupled with a fine-grained super tough substrate for excellent fracture resistance.	ACZ310
M	AC6040M	91,6	3,8	Absotech	3	The first recommended grade for interrupted machining of stainless steel that drastically improves the reliability in unstable machining thanks to the excellent adhesion and peel-off resistance of the new Absotech Bronze PVD coating, as well as the improved fracture resistance of the exclusive ultra-hard carbide substrate.	AC530U
	AC530U	91,4	3,3	Super ZX Coat	3	Heavy interrupted machining and stainless steel machining. Utilizing the super multi-layered PVD coating of nanometre thick TiAlN and AlCrN layers, coupled with a fine-grained super tough substrate for excellent fracture resistance.	ACZ310
S	AC5005S	93,1	2,8	Absotech	5	Grade for high-speed and high-efficiency machining of exotic alloys. The use of a dedicated carbide substrate with great high-temperature strength realises excellent wear resistance in high-speed, high-efficiency machining.	—
	AC5015S	92,7	3,2	Absotech	5	The first recommended grade for turning exotic alloy. Adopts a carbide substrate with excellent thermal resistance and a new coating with excellent wear resistance and chipping resistance, realizing stable long tool life over a wide range of cutting conditions.	AC510U
	AC5025S	91,8	3,6	Absotech	5	For partially interrupted to interrupted machining of exotic alloy. Adopts a carbide substrate with excellent fracture resistance and a new coating with excellent wear resistance and chipping resistance, realizing stable long tool life with unstable cutting conditions.	AC520U
H	AC503U	93,2	1,7	Super ZX Coat	3	For hardened steel. Utilizing the super multi-layered PVD coating of nanometre thick TiAlN and AlCrN layers, coupled with an ultra-hard substrate for excellent wear resistance.	—
Small Product Machining	ACZ150	91,4	3,3	ZX Coat	1	For small tools, and high-precision finishing to general finishing applications. TiN ultra-thin coating and fine-grained, super tough substrate combine to give good edge sharpness and superior cut finish.	—
	AC1030U	91,6	3,8	Absotech	2	For precision machining that supports a wide range of work materials. Employs the new "Absotech Bronze" coating with excellent adhesion and peel-off resistance to deliver excellent machined surface quality with improvements in cutting edge quality and superb stability.	—

For Milling (PVD)

Class	Grade	Hardness (HRA)	TRS (GPa)	Main Coating Components	Coating Thickness (µm)	Characteristics	Old Grades
P	ACU2500	91,6	3,8	Absotech	3	General purpose grade supporting steel, stainless steel and cast iron machining. Adopts a carbide substrate with excellent fracture resistance and wear resistance, plus a new coating with wear and chipping resistance, realizing stable long tool life with various work material grades.	—
	ACP200	89,5	3,2	Super ZX Coat	3	For general machining of general and die steel. Employs PVD coating consisting of multiple nanometre-thin layers. A general grade that achieves a good balance between fracture resistance and wear resistance when combined with an exclusive tough substrate.	ACZ330
	ACP300	89,3	3,1	Super ZX Coat	3	For interrupted machining and stainless steel machining. Employs PVD coating consisting of multiple nanometre-thin layers. Provides excellent fracture resistance when combined with an ultra-tough substrate.	ACZ350
	ACP3000	89,5	3,2	Absotech	3	1st recommended grade for milling steel. Carbide substrate with excellent thermal crack resistance, plus a new coating with excellent wear and chipping resistance, realizes stable long tool life over a wide range of cutting conditions.	ACP200 ACP300
M	ACM100	91,4	3,3	Super ZX Coat	3	A grade that provides excellent wear resistance by employing an ultra-hard fine-grained carbide and New Super ZX Coating.	ACZ310
	ACM300	89,8	3,4	Super ZX Coat	3	The first recommended grade for stainless steel machining that achieves a good balance between wear resistance and fracture resistance by employing a newly-developed ultra-hard carbide and New Super ZX Coating.	—
K	ACK300	91,4	3,3	Super ZX Coat	3	General-purpose grade with an excellent balance of wear and fracture resistance.	ACZ310
	ACK3000	91,7	3,1	Absotech	3	1st recommended grade for milling cast iron. Adopts a high thermal conductivity carbide substrate and a new coating with excellent wear and chipping resistance, realizing stable long tool life over a wide range of cast iron machining operations.	ACK300
N	DL1000	92,9	2,1	AURORA Coat (DLC Coat)	0,5	For milling non-ferrous metal, utilizing DLC coat with a low coefficient of friction and excellent adhesion resistance.	—
	DL2000	91,6	3,8	AURORA Coat (DLC Coat)	0,5	For milling non-ferrous metal, utilizing DLC coat with a low coefficient of friction and excellent adhesion resistance.	—

*There may be minor differences in the colour tone/lustre of Brilliant Coat grades due to the interference of light. Such differences have no effect on performance.

TiC / TaC (Titanium Carbide) Cermet



Various grades and expanded lineup of catalogue items meet a wide range of finishing needs.

Lineup includes wear-resistant T1000A, general purpose T1500A, general purpose coated cermet T1500Z and tough T2500A. Significantly expanded lineup of catalogue items for a wide variety of finishing applications.

Characteristics

Uncoated Cermet

T1000A High Speed Finishing Grade
High speed finishing grade with excellent wear resistance. Improved wear and fracture resistance. Solid solution hard phase reduces reaction with steel. Perfect for high-speed continuous finishing of steel, cast iron and powdered metal.

Coated Cermet

T1500Z New General Purpose Grade
General purpose coated cermet grade that employs new Brilliant Coat* PVD coating with excellent lubricity. Excellent wear resistance provides long tool life. Reduces adhesion of work material for beautiful finished surfaces.

Uncoated Cermet

T1500A
A general purpose grade that provides both wear and fracture resistance with higher-quality surface finish. Mixing hard phases of different functionality, grain size and composition improves balance of wear and fracture resistance. Improved cutting edge treatment technology provides beautiful finished machined surfaces.

Coated Cermet

T2500Z
Tough grade with excellent fracture resistance and thermal crack resistance. Fine, uniform grain structure greatly improves toughness. Improves thermal crack resistance due to the high thermal conductivity and realises long stable tool life. Uses Brilliant Coat, with excellent lubricity to realise excellent machined surface quality.

Characteristic Values

For Turning

Class	Grade	Hardness (HRA)	TRS (GPa)	Coating Type	Coating Thickness (µm)	Characteristics	Old Grades
P	T1000A	93,3	1,8	—	—	Uncoated cermet grade with excellent wear resistance that provides good cost efficiency. Demonstrates excellent wear resistance in continuous finishing applications, and stable finishing of cast iron and sintered alloy as well as steel.	T110A
	T1500A	92,0	2,2	—	—	A general purpose grade that employs a substrate with improved balance of fracture and wear resistance to deliver superior finished surfaces in a wide variety of cutting conditions.	T1200A
	T2500A	91,8	2,4	—	—	For interrupted machining of steel. Fine, uniform grain structure greatly improves toughness, realizing long tool life and excellent surface finish even with interrupted cutting.	—
	T1500Z	92,0	2,2	PVD Brilliant Coat*	3	Brilliant Coat's* new PVD coating gives excellent lubricity for higher quality machining. General-purpose coated cermet grade that can maintain high-quality machined surfaces and also gives excellent wear resistance.	T2000Z
	T2500Z	91,8	2,4	PVD Brilliant Coat*	3	For finishing of steel. The use of Brilliant Coat with excellent lubricity and a tough cermet substrate realises excellent machined surface quality and superb stability.	T3000Z
K	T1000A	93,3	1,8	—	—	Exclusive uncoated cermet grade with excellent cost efficiency suitable for cast iron finishing, which requires high hardness.	T110A

For Milling

Class	Grade	Hardness (HRA)	TRS (GPa)	Coating Type	Coating Thickness (µm)	Characteristics	Old Grades
P	T1500A	92,0	2,2	—	—	A general-purpose grade that employs a substrate with an improved balance between fracture and wear resistance to deliver superior finished surfaces in a wide variety of cutting conditions.	T1200A
	T250A	91,4	2,1	—	—	Tough cermet grade with enhanced crack advancement resistance.	—
M	T2500A	91,8	2,2	—	—	For finishing of steel and stainless steel. Fine, uniform grain structure greatly improves toughness, realizing long tool life and excellent surface finishing.	T250A
	T4500A	91,0	2,3	—	—	For finishing of steel and stainless steel. Tough grade with excellent fracture resistance and reduced thermal cracking.	—

*There may be minor differences in the colour tone/lustre of Brilliant Coat grades due to the interference of light. Such differences have no effect on performance.

WC (Tungsten Carbide) „Igetalloy“

Igetalloy carbides have a solid history and a big variety of grades to suit many different applications. They are widely used and appreciated for their superior performance.

The Igetalloy line-up consists of carbide cutting tools that are available in a variety of different structures and compositions, each differing in terms of WC grain size and containing varying amounts of CO binder and TiC, TaC, and other double carbide components. The wide selection enables excellent wear resistance and toughness with a variety of work materials and cutting conditions.

● For Steel

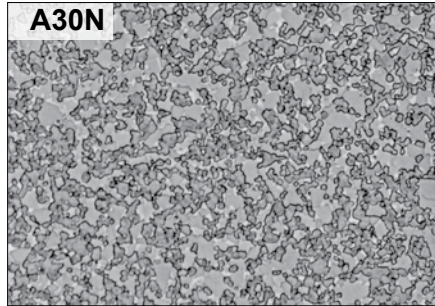

● For Stainless Steel

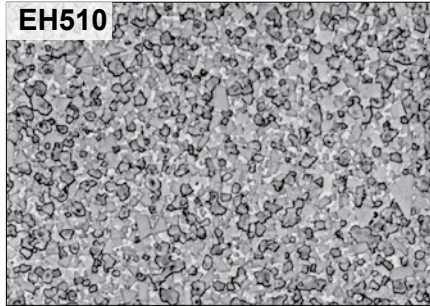

● For Cast Iron

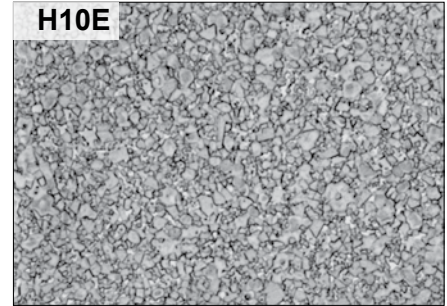

Characteristic Values

Application	Grade	Hardness (HRA)	TRS (GPa)	Young's Modulus (GPa)	Thermal Conductivity (W/m·°C)	Compressive Strength (GPa)	Linear-Thermal Expansion Coefficient (X 10 ⁻⁶ /°C)
P	ST10P	92,1	1,9	470	25	4,9	6,2
	ST20E	91,8	1,9	550	42	4,8	5,2
	A30	91,3	2,1	520	—	—	5,2
	A30N	91,2	2,2	520	—	—	—
	ST40E	90,4	2,6	—	75	—	—
M	EH510	92,6	2,6	—	—	—	—
	EH520	91,7	3,0	—	—	—	—
	A30	91,3	2,1	520	—	—	5,2
	A30N	91,0	2,4	—	—	—	—
K	BL130	94,3	2,9	—	—	—	—
	H2	93,2	1,8	600	105	6,1	4,4
	H1	92,9	2,1	650	109	6,1	4,7
	EH510	92,6	2,6	—	—	—	—
	H10E	92,3	2,0	—	67	—	—
	EH520	91,7	3,0	—	—	—	—
	G10E	91,1	2,2	620	105	5,7	—
N	H1	92,9	2,1	650	109	6,1	4,7
	H20	91,6	3,8	—	—	—	—
S	EH510	92,6	2,6	—	—	—	—
	EH520	91,7	3,0	—	—	—	—

CBN (Cubic Boron Nitride) SUMIBORON



High hardness and heat resistance for cutting high hardness steel and hard cast iron. Long tool life with high-speed finishing of grey cast iron.

In 1977, Sumitomo Electric Hardmetal successfully developed a revolutionary CBN sintered tool - SUMIBORON. The main component in SUMIBORON is Cubic Boron Nitride with a special ceramic binder sintered under super high pressure and temperature. As compared to other conventional tool materials, CBN has higher hardness and excellent heat resistance.

With these distinct characteristics, SUMIBORON can perform machining of hardened steel, high hardness cast iron and exotic metals where previously only grinding was done. Furthermore, excellent efficiency and longer tool life can also be achieved from high speed machining of cast irons.

Characteristics

Classifications	Structure	CBN Content	Hardness (GPa)	Grades	Application	Characteristics
Purely CBN particles, firmly bonded		High	54	NCB100	Cast Iron, Titanium Alloy, Pure Titanium, Co-Cr-Alloy, Cemented Carbide, Cermet	Containing no binder, the nano-to sub-micron CBN particles have a directly bonded structure. The high hardness and thermal conductivity make it highly efficient with a long tool life when machining exotic alloys such as titanium alloys and Co-Cr alloys.
Mainly CBN grains fused together		↑ ↓	↑ ↓	BN7000 BN7500 BN7115 BNC8125 BNS8125 BNS800	Carbide, Chilled cast iron, Ni-Hard cast iron, Heat-resistant alloy, Cast iron Sintered ferrous alloy	High carbon content. Structure consists of strongly fused CBN grains. Suited to cutting cast iron, heat-resistant alloy, ultra-hard alloy, and other hard materials.
Mainly CBN grains held together with a binder				BN1000, BN2000, BN350 BNX10, BNX20, BNX25 BN500, New BNC2115, New BN2010, BN2020 BNC300, BNC100, BNC160 BNC200, BNC500	Alloy steel, Case hardened steel, Carbon tool steels, Bearing steel, Die steel, Ductile cast iron	CBN grains are fused together strongly with a special ceramic binder. Strong CBN binding force gives superior wear resistance and toughness when cutting hardened steel and cast iron.

Grade Range Map

Class	Application	High-speed Cutting	Finishing – Light Cutting	Medium Cutting	Rough – Heavy Cutting	
H	Classification	–	H01	H10	H20	H30
	Coated SUMIBORON			BNC2115 New	BNC2125 New	
			BNC2010		BNC2020	BNC300
			BNC100		BNC160	
					BNC200	
			BN1000			
	Uncoated SUMIBORON		BNX10	BN2000	BNX20	BN350
		Classification	–	01	10	20
	Sintered Components	Uncoated SUMIBORON		BN7115 New	BN7000	
		Coated SUMIBORON		BNC500*		BNC8115 New
			NCB100			
				BN500		
				BN7000		
K	Uncoated SUMIBORON				BNS8125 New	
					BNS800	
	Classification	–	S01	S10	S20	S30
		Uncoated SUMIBORON		NCB100	BN7000	BNS8125 New

* Dedicated for Ductile Cast Iron.

CBN (Cubic Boron Nitride)

SUMIBORON

Characteristic Values

Class	Grade	Binder	Carbon Content (%)	Grain Size (µm)	Hardness HV (GPa)	TRS (GPa)	Main Coating Components	Coating Thickness (µm)	Characteristics
	New BNC2115	TiN	60–65	3	31–33	1,3–1,4	TiAlSiN super multilayered coating	3	Maintains excellent surface roughness thanks to coating with high notch wear resistance and tough CBN substrate
	New BNC2125	TiN	65–70	4	33–35	1,5–1,6	TiAlSiN super multilayered coating	3	Along with a tough CBN substrate, the coating combines wear resistance and toughness to achieve even more stable machining.
H	BNC2010	TiCN	50–55	2	30–32	1,1–1,2	TiCN multi-layered	2	Improves the wear resistance of coating and substrate and stably achieves excellent surface roughness.
	BNC2020	TiN	70–75	5	34–36	1,4–1,5	TiAlN multi-layered	2	Provides long tool life in general and high-efficiency cutting thanks to tough substrate coated with a highly wear-resistant and highly adhesive layer.
	BNC100	TiN	40–45	1	29–32	1,0–1,1	TiAlN	3	Highly wear resistant coating makes this grade suited for high speed finishing.
	BNC160	TiN	60–65	3	31–33	1,2–1,3	TiAlN/TiCN	3	Stable, high precision finishing of hardened steel.
	BNC200	TiN	65–70	4	33–35	1,4–1,5	TiAlN/TiCN	3	Tough substrate with high wear resistant coating provide longer tool life.
	BNC300	TiN	60–65	1	33–35	1,5–1,6	TiAlN	1	Suited for finishing when there is a combination of continuous and interrupted cutting.
	BNX10	TiCN	40–45	3	27–31	0,9–1,0	–	–	Optimum wear resistance. Suited to continuous, high-speed cutting.
	BN1000	TiCN	40–45	1	27–31	0,9–1,0	–	–	Ultimate wear and fracture resistance. Suited to high-speed cutting.
	BNX20	TiN	55–60	3	31–33	1,0–1,1	–	–	Crater resistant grade, suitable for high efficiency cutting under high temperature conditions.
	BNX25	TiN	65–70	4	29–31	1,0–1,1	–	–	Excellent fracture resistance during high speed cutting. Suited to high speed interrupted cutting of hardened steel.
	BN2000	TiN	50–55	2	31–34	1,1–1,2	–	–	A general purpose grade for hardened steel that provides a high degree of fracture and wear resistance.
	BN350	TiN	60–65	1	33–35	1,5–1,6	–	–	High cutting edge strength. suited to heavy interrupted cutting.
Sintered Components	New BN7115	Co Compound	90–95	1	41–44	2,2–2,3	–	–	Grade balancing ultimate cutting edge sharpness with fracture resistance, suitable for finishing of sintered alloy.
	BN7500	Co Compound	90–95	1	41–44	2,0–2,1	–	–	Maintains optimum cutting edge sharpness. Suited for finishing of sintered alloy.
	BN7000	Co Compound	90–95	2	41–44	1,8–1,9	–	–	Improved wear and fracture resistance in rough cutting of sintered components.
K	New BNC8115	Al Alloy	85–90	8	39–42	0,95–1,15	TiAlN	2	Grade with 100% solid CBN structure, using PVD coating with excellent wear resistance to enable roughing operations.
	New BNS8125	Al Alloy	85–90	8	39–42	0,95–1,15	–	–	Grade with 100% solid CBN structure that exhibits excellent wear and fracture resistance.
	BN7000	Co Compound	90–95	2	41–44	1,8–1,9	–	–	Improved wear and fracture resistance in rough cutting of cast iron and exotic alloy.
	BNS800	Al Alloy	85–90	8	39–42	0,9–1,1	–	–	100% solid CBN structure with good thermal impact resistance.
	BNC500	TiC	60–65	4	32–34	1,1–1,2	TiAlN	3	Substrate with excellent wear resistance and coating makes this grade suited for hard-to-cut cast iron.
S	NCB100	–	100	–0,5	51–54	1,8–1,9	–	–	Achieves high-efficiency, improved machining accuracy and long tool life in machining of exotic alloys such as titanium alloy and Co-Cr alloys.

PCD (Polycrystalline Diamond) SUMIDIA

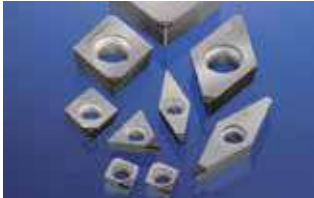

Excellent wear resistance, longer tool life, and high-speed, high-efficiency, high-precision cutting of non-ferrous metals and non-metals.

SUMIDIA is a polycrystalline diamond material made from sintered diamond powder that was first created using our proprietary technology in 1978.

SUMIDIA's superior wear resistance achieves longer tool life, high speed, high efficiency and high precision in non-metal cutting and non-ferrous metal applications including aluminium, copper, magnesium and zinc alloys.



SUMIDIA Binderless uses nano-polycrystalline diamond for the cutting edge, demonstrating excellent wear resistance and fracture resistance.

In particular, it achieves extended tool life and machining accuracy superior to conventional polycrystalline diamond when machining hard brittle materials such as cemented carbides.

Features

Diamond particles on the order of sub-microns to several dozen microns, sintered at high density.

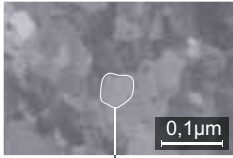
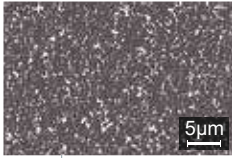
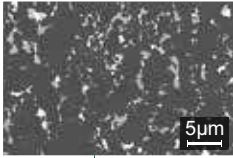
Structure

SUMIDIA Binderless	SUMIDIA		
NPD10	DA1000	DA150	DA90
			
Diamond particles	Black areas in image are diamond particles.		

Grade Range Map

Class	Series	Finishing – Light Cutting		Medium Cutting	Rough – Heavy Cutting
Brittle Materials	Classification	01	10	20	30
	SUMIDIA Binderless	NPD10			
	SUMIDIA		DA90		
N	Classification	N01	N02	N20	N30
	SUMIDIA	DA1000			
		DA150			
		DA90			

Characteristic Values

Class	Grade	Binder	Carbon Content (%)	Grain Size (µm)	Hardness HV (GPa)	TRS (GPa)	Characteristics
Brittle Materials	NPD10	Co	100	<=0,05	120–130	≈ 3,15	100% diamond that directly binds nano-order diamond particles with high strength. Demonstrates optimum wear and fracture resistance as well as the best edge sharpness.
N	DA1000	Co	90–95	–0,5	110–120	≈ 2,60	High density sintered material made of ultra-fine diamond particles that demonstrates optimum wear and fracture resistance, and edge sharpness.
	DA150	Co	85–90	5	100–120	≈ 1,95	Sintered material made of fine diamond particles that provides a good balance of workability and wear resistance.
	DA90	Co	90–95	50	50–65	≈ 1,10	Coarse sintered diamond particles, with high diamond content for excellent wear resistance.

PCD (Polycrystalline Diamond) SUMIDIA Binderless

Grades



SUMIDIA Binderless Series uses nano-polycrystalline diamond for the cutting edge and demonstrates excellent wear and fracture resistance compared to conventional sintered diamond tools.

In particular, SUMIDIA Binderless Series allows for improvements in tool life and machining precision that go far beyond conventional diamond tools in the machining of hard brittle materials, such as carbide.

Excellent for High Precision Machining of Carbide

Nano-polycrystalline diamond with excellent wear resistance achieves high precision on machining of carbide.

Maintains Superior Dimensional Tolerances Over Many Hours

Greatly reduces the number of tool replacements compared to conventional diamond tools and increases work efficiency while reducing total costs.

Suitable for Hard Brittle Material Machining

Hard brittle materials (such as ceramics) that could only be ground before can now be cut.

Characteristics

Comparison of Structure

Nano-Polycrystalline Diamond
SEM Structure

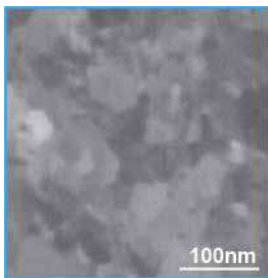

Diamond Particles
(30–50 nm)

Conventional PCD
SEM Structure

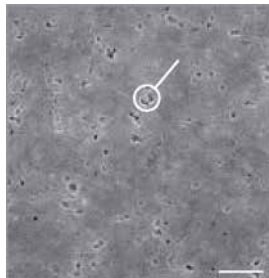

Diamond Particles
(1–10 µm)

Hardness

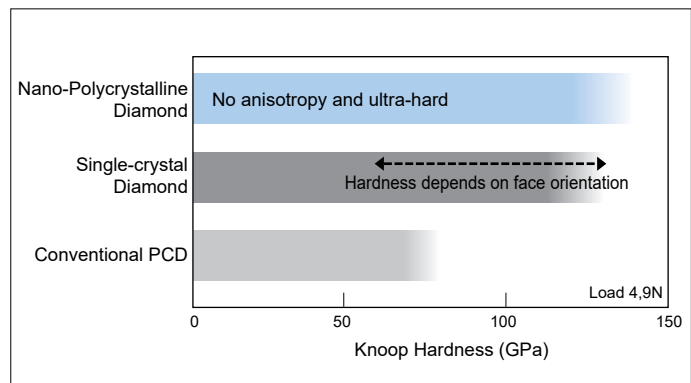

Application (Carbide Machining)

Hardness < 88HRA

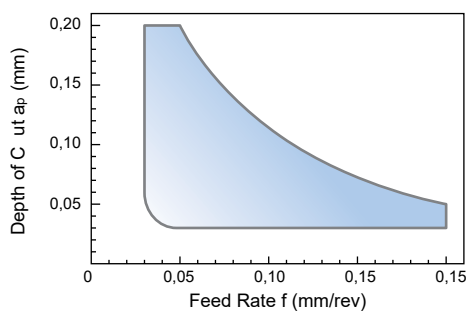

Hardness ≥ 88HRA

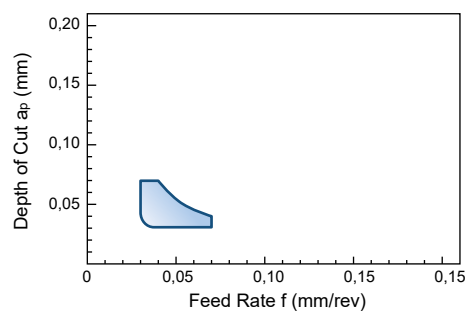

Recommended Cutting Conditions (Carbide Machining)

Coolant: Dry

Min. - Optimum - Max.

Work Material			Cutting Conditions		
Classification	Hardness (HRA)	SEH Grade	Cutting Speed v_c (m/min)	Feed Rate f (mm/rev)	Depth of Cut a_p (mm/rev)
VM VC	70 60 50	G7 G6	5–20–30	0,03–0,10–0,20	0,03–0,10–0,20
VM VC	40	G5 G2	5–15–30	0,03–0,05–0,07	0,03–0,10–0,20

Grade Comparison Chart

Coated Carbide (CVD)

Application	Class	Grade	Sumitomo Electric	Mitsubishi	Tungaloy	Kyocera	MOLDINO	Sandvik	Kennametal	SECO Tools	WALTER	ISCAR	Taegu Tec	NTK	
Turning	P	P05	AC8015P	UE6105 MC6115	T9105 T9205	CA510 CA5505	HG8010	GC4305 GC4205	KCP05 KCP05B	TP0501 TP0500	WPP05S WPP05 WPP01	IC8005 IC8150 IC9015	TT8105		
		P10	AC8020P AC8015P <small>New</small>	MC6115 MC6015 UE6110	T9105 T9115 T9205 T9215	CA510 CA515 CA5515	HG8010	GC4415 GC4305 GC4215 GC4315	KCP10 KCP10B	TP1501 TP1500	WPP10S WPP10	IC8150 IC8080 IC9015 IC9150	TT8115	CP7	
		P20	AC8020P AC8025P <small>New</small>	MC6025 UE6020	T9115 T9125 T9215 T9225	CA025P CA525	GM25 HG8025 GM8020	GC4425 GC4325 GC4225	KCP25 KCP25B	TP2501 TP2500	WPP20S WPP20	IC8150 IC8250 IC9015 IC9150	TT5100 TT8125	CP7	
		P30	AC8035P AC6030M AC630M	MC6035 UE6035	T9125 T9135 T6130	CA025P CA525 CA530	GM25	GC4325 GC4335 GC4235	KCP30 KCP30B	TP3500	WPP30S WPP30	IC8080 IC9350	TT7100 TT8135		
		P40	AC8035P AC6030M AC630M	MC6035	T9135 T9235 T6130	CA530 CA5535	GX30 GM8035	GC4335 GC4235 GC30	KCP40 KCP40B	TP3501 TP3500			IC9350	TT7100	
	M	S	M10 S10	AC6020M	MC7015 US905 US7020	T9115 T9215	CA6515	HS9105	GC2015 GC1515 S05F	KCM15	TM1501		IC9250 IC520M	TT9215 TT3005	
			M20 S20	AC6020M AC6030M AC630M	MC7025 US7020	T6120 T9125 T9215	CA6525	HG8025	GC2025 GC1515	KCM25	TP2501 TM2000 TM2501		IC9025 IC9325 IC4050	TT5100 TT9225	
			M30	AC6030M AC630M AC8035P	MC7025 US735	T6130	CA6535	GM8035 GX30 GM25	GC2035 GC235	KCM35	TP3500 TM3501 TM4000		IC9350 IC4050 IC635	TT9235	
			M40	AC6040M AC630M	US735				GC235 GC2035		TM4000				TT7800
	K	K05	AC4010K	MC5005 UC5105 UC5115	T5105	CA310 CA4505 CA4010	HX3505	GC3205 GC3210	KCK05	TK0501 TK1001	WAK10 WKK10S	IC5005	TT7005 TT7505	CP1	
		K10	AC4010K AC4015K	MC5005 MC5015 MC5020 UC5105 UC5115	T515 T5105 T5115	CA315 CA4505 CA4515 CA4115	HX3305 HX3515 HG8010	GC3210	KCK15	TK1000 TK1001	WAK10 WAK20 WKK10S WKK20S	IC5100 IC9150 IC4100	TT7015	CP1	
		K20	AC4015K AC420K AC425K AC8025P	MC5015 UC5115 UE6110	T515 T5125 T9125	CA320 CA4515 CA4120 CA4115	HX3315 GM8020	GC3225	KCK15 KCK20	K2001	WAK20 WAK30 WKK20S	IC9150 IC5100 IC4100	TT7015		
	Milling	P	P10	XCU2500 ACP2000 ACP100 <small>New</small>	FH7020 F7030 MV1020	T3130 T3030			GC4220 GC4330	KCPM20	MP1501 MP1500 MP2501 MP2500	WKP25 WKP25S WPP35G WKP35S	IC4100 IC5400 IC9015 IC8080 IC9080	TT7080 TT7515 TT9300	
			P20	XCU2500 ACP2000, ACP100 <small>New</small>	F7030				GC4330 GC4340	KCPM20 KCPK30	MP2501 MP2500	WKP25 WKP25S	IC8080 IC9080	TT7400	
			P30	XCU2500 ACP2000, ACP100 <small>New</small>	F7030				GC4340	KCPK30 KCMP30			IC9250 IC4050	TT7800 TT8525	
		M	S	M10	XCU2500 ACM100 <small>New</small>										
M20				XCU2500 ACM200	F7030	T3130	CA6535	GX2160 AX2040	GC2040		MS2500	WKP35S		TT7800	
M30				XCU2500 ACM200	F7030						KC994M		IC5820	TT7800	
K		K10	XCK2000 ACK2000 ACK200 <small>New</small>							KCK15			IC5100	TT7515	
		K20	XCK2000 XCU2500 ACK2000 ACK200 <small>New</small>	MV1020 MC5020 F5010 F5020	T1115	CA420M	GX2120	GC3330 GC3220 GC3225 GC3020 GC3040	KC915M KC930M KC935M	MK1500	WAK15 WKP25S	IC5100 DT7150 IC4010 IC4050 IC4100	TT6800 TT7080		

Coated Carbide (PVD)

Application	Class	Grade	Sumitomo Electric	Mitsubishi	Tungaloy	Kyocera	MOLDINO	Sandvik	Kennametal	SECO Tools	WALTER	ISCAR	Taegu Tec	NTK	
Turning	P	P10	ACZ150 AC1030U AC5005S AC5015S AC5025S <small>New</small>	VP15TF MS6015	AH710 AH110 AH120 AH725	PR915 PR1005 PR930 PR1215 PR1225 PR1705		GC1525	KCU10 KC5510	TS2000	WSM10	IC507 IC807 IC907		TM1 VM1 DT4 DM4	
		P20	AC1030U AC5025S AC530U	VP15TF VP20RT	AH120 AH725 AH3135	PR1225 PR1425	IP2000	GC15 GC1125	KCU25				IC807 IC808 IC810	TT9080	TM1 TM4 VM1 QM3 DM4
		P30	AC1030U AC530U	VP15TF VP20RT	AH120 AH725 SH730 AH730	PR1425 PR1525 PR1535	IP3000 CY250	GC1125					IC328 IC928	TT8020 TT9030	QM3
		P40	AC1030U				PR660	IP3000	GC4335 GC4235				IC830	TT8020	

Grade Comparison Chart

Coated Carbide (PVD)

Application	Class	Grade	Sumitomo Electric	Mitsubishi	Tungaloy	Kyocera	Mitsubishi-Hitachi	Sandvik	Kennametal	SECO Tools	WALTER	ISCAR	Taegu Tec	NTK		
Turning	M S	M10 S10	AC5005S AC5015S AC5025S ACZ150	New MP9005 MP9015 VP15TF VP05RT VP10RT	AH110 AH710 AH725 AH905 AH8005	PR005S PR015S PR915 PR1025 PR1215 PR1225 PR1305 PR1310	IP050S IP100S JP9105 JP9115	H5D6 GC1105 GC1115	KCS10 KCS10B KC5510 KCU10	TH1000 TS2000	WSM01 WSM10 WSM10S	IC804 IC807 IC808 IC907 IC908	TT5080 TT3010 TT8010	TM1 VM1 DT4 DM4 ZM3 ST4		
		M20 S20	AC1030U AC5015S AC5025S	MP9015 MP9025 VP15TF VP20RT VP20MF UP20M MS9025	AH630 AH120 AH725 AH8015	PR015S PR915 PR930 PR1025 PR1125 PR1215 PR1225 PR1325	IP100S HS9115	GC15 GC1115 GC1125	KC5525 KCU25 KC5025	TS2500	WSM20 WSM20S	IC330 IC806 IC808 IC830 IC908 IC928	TT9080 TT9020 TT3020	DT4 DM4 ZM3 QM3 TM4 ST4		
		M30	AC5025S AC6040M AC530U AC1030U	MP7035 VP15TF VP20MF MS9025	AH630 AH645 AH725	PR1125 PR1525 PR1535			GC1125			WSM30 WSM30S	IC328 IC330 IC830 IC840 IC882	TT8020 TT8080 TT9080	QM3 TM4 DT4 DM4	
		M40	AC6040M AC530U AC1030U	MP7035 VP15TF MS6015	AH645	PR1125 PR1535	GX30						IC830 IC928	TT8020 TT8080		
	K	K10	ACZ150 AC1030U AC5015S	VP10RT	AH110 AH120	PR905	HX3305 HG3305 HG3315 HX3515 HG8010 TH315		GC15				IC810	TT6080		
		K20	ACZ150 AC1030U AC5015S AC5025S	VP10RT VP20RT VP15TF	AH120	PR905									TT6080	DM4 QM3
		K30	AC1030U AC530U	VP15TF VP20RT	AH110 AH120 AH725								IC830 IC908 IC910 IC928			
	Milling	P	P10	ACU2500 ACP200	VP15TF MP6120	AH110 AH120 AH710 AH725	PR1225	PN215 PN15M JP4105 JP4115 JP4120 CY9020	GC1010	KC505M KC510M KC515M	F25M		IC807 IC903	TT2510 TT7080	DT4 DM4	
			P20	ACP3000 ACU2500 ACP200 ACP300	VP15TF VP20RT MP6120 MP6130 UP20M	AH9030 AH120 AH725 AH3035 AH3225	PR1525 PR1225 PR1230 PR830	JP4120 CY150 CY1230 JS4045	GC1010 GC1025	KC522M KC525M KCSM30 SP6519	MP3000 F30M F32M F40M	WSM20 WSM20S	IC808 IC810 IC908 IC910	TT7080 TT9030 TT9080	TM4 DT4 DM4	
			P30	ACP3000 ACU2500 ACP200 ACP300	VP15TF VP30RT MP6130 UP20M	AH3035 AH3135 AH3225 AH120 AH130 AH140 AH725	PR1525 PR1230 PR830	JS4045 JS4060 CY25 CY150 CY250 CY250V PTH30E		GC1030 GC1130 GC2030	KC725M KC735M KC525M KC530M KCPM40 KCSM30 SP6519	F40M T60M MP3000	WSM35 WSM35S WSP45 WSP45S	IC328 IC330 IC830 IC928	TT8080 TT8020	DM4 TM4 ZM3
P40			ACP3000 ACU2500 ACP300	VP30RT	AH140		JS4060 JM4160 PTH40H			KC725M KC735M KCPM40		WSP45 WSP45S	IC830 IC845 IC928	TT8020 TT8080 TT8525B		
M		M10 S10	ACM100 ACU2500 ACK300 ACP300	MP9120 VP15TF	AH110 AH120 AH330 AH725 AH8005 AH8015	PR1025 PR1225	CY9020 JP4120 PN08M PN15M PN208 PN215	GC1010 GC1025 GC1030 GC1130	KC515M SP4019 SP6519				IC808 IC908		DT4 DM4 ZM3	
		M20	ACM300 ACU2500 ACP300	MP7030 MP7130 MP9120 MP9130 UP20M VP15TF VP20RT	AH120 AH130 AH330 AH725 AH3225 AH8015	PR1210 PR1225 PR1525 PR830	JP4120 CY150 JS1025	S30T	KC522M KC525M SP4019 SP6519 X700	F25M F30M T32M MP3000 MS2050 MM4500	WSM35 WSM35S	IC328 IC330 IC808 IC830 IC840 IC908 IC928	TT9080 TT9030	DT4 DM4 ZM3		
		M30	ACM300	MP7030 MP7130 MP7140 MP9130 VP15TF	AH130 AH140 AH330 AH725 AH3135	PR1525 PR1535 PR830	JM4160 PTH30E JS1025	GC2030 GC1040 S40T	KC522M KC525M KC725M KCPM40 KCSM30	F30M F32M F40M MP2050 MS2050	WSM35 WSM35S WSP45 WSP45S	IC328 IC330 IC830 IC840 IC882	TT8020 TT8080 TT9080	DT4 DM4 ZM3		
		M40	ACM300	MP7140 MP9140 VP30RT	AH140	PR1535	JM4160 PTH40H			KC725M KCPM40 KCSM40		WSP45 WSP45S	IC328 IC330 IC882	TT8020 TT8080		
K		K05	ACK3000	MP8010	AH110 AH710		TH303 TH308 ATH80D		GC1010	SP4019	MH1000					
		K10	ACK3000 ACU2500	MP8010	AH110 AH120	PR1210	ATH10E TH315		GC1010 GC1020	KC514M SP4019	MH1000		IC810 IC910	TT7080 TT7515		
		K20	ACK3000 ACU2500 ACK300	MP8010 VP15TF	AH110 AH120 AH330 GH330	PR1210 PR1510	JP4120 PTH13S CY100H CY9020		GC1020 GC1025	KC514M KC524M KCK20 SP6519	MK2050 MK3000	WKK25S	IC808 IC810 IC830 IC908	TT6080 TT7515	DM4	
		K30	ACK3000 ACU2500 ACK300	VP15TF VP20RT	AH725 AH120 AH330 GH110 GH130 GH330	PR1510 PR1210	JS4045 CY150 CY250		GC1025 GC1030 GC1130	KC520M KC522M KC524M	MK2050		IC830 IC810 IC910 IC928	TT6080		

Grades

Grade Comparison Chart

■ Cermet

Application	Class		Sumitomo Electric	Mitsubishi	Tungaloy	Kyocera	MOLDINO	Sandvik	Kennametal	SECO Tools	WALTER	ISCAR	Taegu Tec	
Turning	P	P10	T1500Z* T1000A T1500A	AP25N* NX2525 VP25N*	GT720* GT9530* GT9535* J9530* NS520	TN30 TN6020 TN610 TN620 PV710* PV720* CCX*	CZ25* CH550	CT5015	KT125 HTX KT1120			IC20N IC30N IC520N	PV3030 PV3010 CT3000	
		P20	T1500Z* T2500Z* T3000Z* T1500A T2500A	AP25N* NX2525 NX3035 MP3025*	AT9530* NS9530 GT9530* J9530*	TN90 TN620 TN6020 PV720* CCX*	CZ25* CH550	GC1525*	KT6215 KT315* KT175 KT5020*	CM CMP C15M TP1020			IC20N IC30N IC520N IC530N	CT7000
		P30	T2500Z* T3000Z* T2500A	MX2525 MP3025* VP45N	NS9530 GT9530* AT9530*	TN620 PV720* PV730*								
Milling	P	P30	T2500A T250A T4500A	NX2525 MX3030 NX4545 VP45N*	NS540 NS740	TN60 TN90 TN100M TN620M	MZ1000* MZ2000* MZ3000* CH7030 CH7035	CT530	KT530M* KTPK20*	C15M		IC30N		
		K10	T1000A	AP25N* VP25N* NX2525	GT720* GT9530* NS9530 J9530* NS520	TN610 PV7005* PV7010* CCX*	CH550	CT5015	KT125 HTX					PV3030 CT3000

* denotes coated cermet

■ Uncoated Carbide

Class	Grade	Sumitomo Electric	Mitsubishi	Tungaloy	Kyocera	MOLDINO	NTK	Sandvik	Kennametal	SECO Tools	ISCAR	Taegu Tec
P	P10	ST10P		TH10		WS10		S1P				
	P20	ST20E	UTi20T	KS20		EX35		SMA	K125M		IC70 IC50M	UF10
	P30	A30N	UTi20T	KS15F UX30	PW30	EX35 EX40		SM30			IC54 IC28	P30
	P40	ST40E		TX40		EX45		S6			IC54 IC28	
M	M10	EH510		TH10		EX35 WA10B	KM1	H10A	KU10 K313 K68 KYSM10	890	IC07 IC08 IC20	
	M20	EH520	UTi20T	KS20		EX35		H13A	K313 K68	HX 883	IC07 IC08 IC20	UF10
	M30	A30 A30N	UTi20T	UX30				H10F SM30			IC28	
K	K01	H2 H1	HTi05T	KS05F		WH01 WH05			KU10 K68 K313 K115M		IS8	
	K10	H1 EH510	HTi10	TH10	KW10 GW15	WH10	KM1	H13A	KU10 K313 K68 K115M K110M KY3500	890	IC20 IS8	K10
	K20	G10E, H10E EH520	UTi20T	KS15F KS20	GW25	WH20	KM3	H13A	KMF KY3500 KYHS10	890 883 HX	IC20 IS8	
	K30	G10E, H10E	UTi20T			WH30			KY3500	883		
S	S10 S20	EH510 EH520	RT9005 RT9010 MT9015 TF15	TH10 KS05F KS15F KS20	SW05 SW10 SW25 KW10 GW15	WH10		H10A H10F H13A	KU10 K313 K68 KMF K110M K1025 KYHS10	HX H25	IC20 IC07 IC08 IC28	K10
	Fine-grained Carbide	A1		UM		NM25		N6F H10F		883	IC08	

Grade Comparison Chart

Grades

■ CBN

Class	Grade	Sumitomo Electric	Mitsubishi	Tungaloy	Kyocera	NTK	Chukyo	Sandvik	Kennametal	SECO Tools	ISCAR
K	K01	NCB100 BNC500* BN7000 BN500	MB710 MB5015	BX930 BX870 BX910	KBN475 KBN60M	B30 B16		CB7525 CB7925	KB1340		IB50 IB85
	K10	BN7000 BN500	MB710 MB730 MB5015 MB4020	BX470 BX480 BX950	KBN60M KBN900	B23 B16	HB55 HB56 HB569 HB580 HB57	CB7925		CBN200 CBN300 CBN300P CBN400C	IB55 IB90
	K20	BN700 BN7000 BNS800	MB730 MB4020 MB4120 MBS140	BX470 BX480 BXC90 BX90S	KBN900		HB56 HB569 HB580 HB57				
	K30	BNC8115 BNS8125 <small>New</small>	MBA4120 MBS140 BC5030	BX90S BXC90			HB57		KB5630	CBN500	
S	S01	NCB100 BN7000	MB730 MB4020 MB4120	BX940 BX950 BX470 BX480			HB55 HB580 HB52		KB5630 KB1340		IB85 IB05S IB10S
H	H01	BNC2010 BNC2115 BN1000 BN2000 <small>New</small>	BC8105 BC8110 MBC010 MB810 MB8110	BXA10 BXM10 BX310	KBN05M KBN25M KBN510	B5K B52	HB55 HB550 HB580 HB590	CB7105	KB5610	CH0550 CBN10 CBN100 CBN60K	IB05H IB50 IB10HC
	H10	BNC2010 BNC2020 BNC2115 BNC2125 BN2000 <small>New</small>	BC8110 BC8120 MBC020 MB8025 MB8110 MB825	BXA10 BXM10 BX330 BX530	KBN05M KBN25M KBN525	B5K B6K B52 B36	HB55 HB59 HB550 HB580 HB52	CB7015 CB7115 CB20	KBH20 KB5610 KB5625	CBN10 CBN150 CBN100 CBN060K CBN160C	IB10H IB55 IB25HA
	H20	BNC2020 BNC2125 BNX20 <small>New</small>	BC8120 BC8020 MBC020 MB8025 MB8120	BXA20 BXM20 BX360	KBN30M KBN35M KBN900	B36 B40 B6K	HB57 HB59 HB590 HB580	CB7025 CB7125 CB50	KBH20 KB5625 KB5630	CH2540 CBN150 CBN160C	IB20H IB20HC IB25H IB25HC
	H30	BNC300 BN350 BNX25	MB835 MB8130 BC8130	BXM20 BXA20 BXC50 BX380	KBN30M KBN35M KBN900	B40	HB57 HB580	CB7525 CB7135	KB5630	CH3515	IB90

■ PCD

Class	Grade	Sumitomo Electric	Mitsubishi	Tungaloy	Kyocera	NTK	Chukyo	Sandvik	Kennametal	SECO Tools	ISCAR
N	N01	DA90 DA1000	MD205	DX180 DX160	KPD001	PD1		CD05 CD10	KD1400		ID5
	N10	DA150 DA1000	MD205 MD220	DX140	KPD001 KPD010 KPD230	PD2	HD100 HD30 HD60	CD1810	KD1400 KD1425	PCD05 PCD10	ID5
	N20	DA1000 DA2200	MD220 MD230	DX120 DX110	KPD230	PD2	HD100 HD30 HD50		KD1400 KD1425	PCD05 PCD20	
	N30	DA1000 DA2200	MD2030 MD230	DX110			HD30 HD50 HD700 HC100		KD1400	PCD05 PCD30 PCD30M	